

**RUSSELL COUNTY**  
**BOARD OF SUPERVISOR’S MEETING**  
**AGENDA – September 7, 2021**

---

**RC Conference Room**

**Regular Meeting**

**6:00 PM**

---

**Russell County Governmental Center**  
**Lebanon, Virginia 24266**

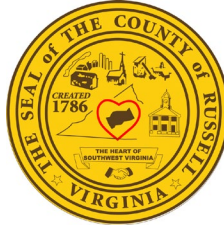

---

**CALL TO ORDER & ROLL CALL – Clerk of the Board**

**INVOCATION – Chairperson**

**PLEDGE OF ALLEGIANCE TO THE FLAG OF THE UNITED STATES OF AMERICA**

**APPROVAL OF AGENDA**

**RECOGNITION**

- 1. Lebanon High School 2021 VHSL Group 2A Baseball Team – State Champions**
- 2. Lebanon High School 2021 VHSL Varsity Softball Team**
- 3. StreamSweepers – Clinch River Project**

**PUBLIC HEARINGS**

- 1. Alternative Public Educational Programs – School Choice**

**NEW BUSINESS**

- 1. Approval of Minutes. Consider approval of the minutes of the following meeting of the Russell County Board of Supervisors.....A-1**
  - a. Unapproved minutes of August 2, 2021**

- 2. Approval of Expenditures. Consider approval of expenditures presented for payment.....A-2
- 3. Committee Appointments for Board Consideration (Tabled).

County Advisory Committee

(1) Appointment Per Board Member

RC Planning Commission

Charles Edmonds	Four-Year Term	April 3, 2021
Roger Sword	Four-Year Term	December 31, 2020

Cumberland Plateau Economic Development Commission

Frank Horton	One-Year Term	June 30, 2021
Tony Lambert	One-Year Term	June 30, 2021
Ron Blankenship	One-Year Term	June 30, 2021
James Eaton, Jr.	One-Year Term	June 30, 2021

Dante Community Center

Jason Gullett	Two-Year Term	June 30, 2021
---------------	---------------	---------------

Russell County Library Board

Karen Herndon	Four-Year Term	June 30, 2021
Ann Monk	Four-Year Term	June 30, 2021
Judy Ashbrook	Four-Year Term	July 10, 2021

RC Highway & Safety Committee

Gary Dotson	Two-Year Term	July 1, 2021
Johnny Jessee	Two-Year Term	July 1, 2021
Steve Dye	Two-Year Term	July 1, 2021
Eugene Ferguson	Two-Year Term	July 1, 2021
Tony Maxfield	Two-Year Term	July 1, 2021
Mike O'Quinn	Two-Year Term	July 1, 2021
Barbara K. Cox	Two-Year Term	July 1, 2021
Henry E. Stinson, Jr.	Two-Year Term	July 1, 2021
Carl Rhea	Two-Year Term	July 1, 2021
Emory Altizer	Two-Year Term	July 1, 2021



**Community Policy Management Team**

Angela Farmer                      Three-Year Term                      August 3, 2021

**Dante Community Center**

Catherine Pratt                      Two-Year Term                      August 5, 2021

**Southwest Community College Advisory Board**

Lynn Keene                      Four-Year Term                      August 7, 2021

Gregory Brown                      Four-Year Term                      August 7, 2021

**RC Industrial Development Authority (IDA)**

Roger Sword                      Four-Year Term                      September 7, 2021

Scott Gilmer                      Four-Year Term                      September 7, 2021

**CITIZEN’S COMMENT PERIOD (Limited to 3 minutes)**

**CONSTITUTIONAL OFFICER REPORTS AND REQUESTS**

**COUNTY ATTORNEY REPORTS AND REQUESTS.....B-1**

- 1. Project Jonah Interjurisdictional Agreement

**COUNTY ADMINISTRATOR REPORTS AND REQUESTS**

**REPORTS**

- 1. RC Sanitary Landfill – Leachate Storage Tank Operations.....C-1
- 2. VDOT September 2021 BOS Update Report.....C-2
- 3. COV Auditor of Public Accounts – Clerk of Circuit Court.....C-3

**REQUESTS**

- 4. VDOT Rte. 637 Discontinued Bridge & Prescriptive Easement.....C-4  
Right-of-Way – 30 ft. width & 0.02-mile length
- 5. RC IDA AFID Grant – Project Brown.....C-5
- 6. Supreme Court of VA Drug Treatment Court Docket Grant - \$90,000.....C-6

- 7. Three Rivers Destination Center – Professional Consulting Services RFQ.....C-7
- 8. VA Department of Criminal Justice Services Grant - \$70,000.....C-8
- 9. RC Disposal Truck Surplus.....C-9

**MATTERS PRESENTED BY THE BOARD**

**ADJOURNMENT**

**COUNTY AGENCY / BOARD REPORTS:**

- Treasurer’s Report.....D
- RC IDA .....E
- RC PSA .....F
- Castlewood W&S .....G
- RC Tourism.....H
- RC Planning Commission .....I
- RC Conference Center.....J
- RC Fitness Center.....K
- RC Transportation & Safety.....L
- RC Cannery Reports.....M
- RC Building Inspector.....N
- RC Disposal.....O
- RC Litter.....P



**Board of Supervisors**  
137 Highland Drive  
Lebanon, VA 24266

Information Item  
Presenters - Various

**Meeting: 9/7/21 6:00 PM**

---

## **Recognition**

- 1. Lebanon High School 2021 VHSL Group 2A Baseball Team – State Champions**
- 2. Lebanon High School 2021 VHSL Varsity Softball Team**
- 3. StreamSweepers – Clinch River Project**

### **Staff Recommendation:**

Presentation – Informational Only.

### **Suggested Motion:**

Board Discretion.

### **ATTACHMENTS:**

- Various



*Lebanon High School*

*2021 VHSL*

*Group 2A Baseball State Champions*

In Recognition

of

**Outstanding Sportsmanship**

and

**Determination to Win State Title**

Awarded by

**Russell County Board of Supervisors**

*Rebecca J. Dye*

CHAIR





*Lebanon High School*

*2021 VHSL*

*Varsity Softball Team*

*Class 2 Final Four*



**In Recognition**

of

**Outstanding Sportsmanship and Achievement**

Awarded by

*Rebecca J. Dye*

CHAIR

**Russell County Board of Supervisors**



# SHOWING at WOODFORD CLASSIC

of the NJCAA. e a member of ristian College ion (NCCAA). st away match f. Aug. 28 at Davidson- g off a strong n which they an 11-5 over- ll to Sandhills 10 Tournament

gles play their gence game on against Patrick

## Schedule

1:00 PM  
5:00 PM  
12:00 PM  
6:30 PM  
2:00 PM  
2:00 PM  
6:30 PM

1:00 PM  
3:00 PM  
12:00 PM  
2:00 PM  
2:00 PM  
6:30 PM  
12:00 PM  
4:00 PM  
6:00 PM  
12:00 PM  
4:00 PM  
6:00 PM  
TBA  
TBA

WYTHEVILLE, Va., (August 3, 2021) – Castlewood opened the golf season with a strong showing in the Woodford Classic at Wytheville Golf Club on Tuesday. The Blue Devils finished in fourth place, the top showing in Class 1. The defending Class 1 champ, George Wythe finished in 10th place.

Jacob Lasley shot a 76 and Coleman Cook finished with a 78 to lead Castlewood.

Defending Class 3 state champion, Abingdon won the tournament.

Below are the complete results.

### WOODFORD CLASSIC

#### Team Scores

Abingdon 292, Floyd County 307, Blacksburg 311, Castlewood 321, Radford 332, Marion 339,

Gate City 353, Rural Retreat 365, Union 382, George Wythe 387, Grayson County 396, Patrick Henry 405, Chilhowie 412, Holston 492, Northwood Inc.

#### Individual Results

1. Abingdon – Grace Addison 70, Conner Brummitt 73, Katie Hall 74, Will Watson 75.

2. Floyd County – McKenzie Weddle 70, Ryne Bond 73, Dylan Bond 81, Corey Powers 83.

3. Blacksburg – Sean Ruan 66, Pierce Campbell 80, Emerson Keene 82, Lishu Wang 83.

4. Castlewood – Jacob Lasley 76, Coleman Cook 78, Abby Bradley 81, Connor Robinette 86.

5. Radford – Jack Davis 80, Graham Minarik 82, Brody Shull 85, Lucas Beeler 85.

6. Marion – Grayson Sheets 76, Tyler Sayers 79, Ethan Bagett 92, Trey Lefley 92.

7. Gate City – Ethan Dishner 82, Zach Taylor 82, Evan Lane

88, Eli McMurray 101.

8. Rural Retreat – Bryce Tibbs 82, Ben Musser 91, Logan Miller 93, Joey Olender 99.

9. Union – Luke Slagle 86, Jacob Day 96, Alexa Barnett 100, Ethan Rich 100.

10. George Wythe – Benson Blevins 72, Reece Vaught 93, Tyler Scott 109, Josh Crigger 113.

11. Grayson County – Madison Carrico 89, Matt Rector 96, Ryan Smith 104, Andrew Shaffner 107.

12. Patrick Henry – Savanna Riley 97, Carter Lester 98, Isaac Presley 101, Caleb Holley 109.

13. Chilhowie – Chase Coley 79, Will Barnes 94, Jordan Elrod 118, Will Goodwin 121.

14. Holston – Cade Morrison 99, Molly Turner 125, Colton Woodward 128, Nathan Bock 140.

15. Northwood – Skylar Thompson 85, Chris Salyer 100, Molly Holmes 102.

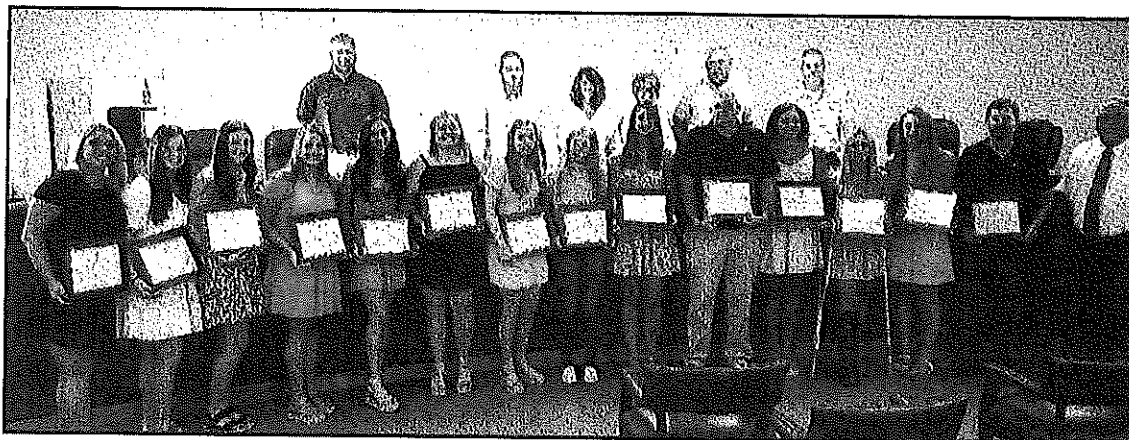

CONTRIBUTED Photos

The Lebanon Town Council recently honored the Lebanon Pioneer softball team (above) for advancing to the VHSL Class 2 Final Four and the Lebanon Pioneer baseball team (below) for claiming the Class 2 State Championship, the first in school history.

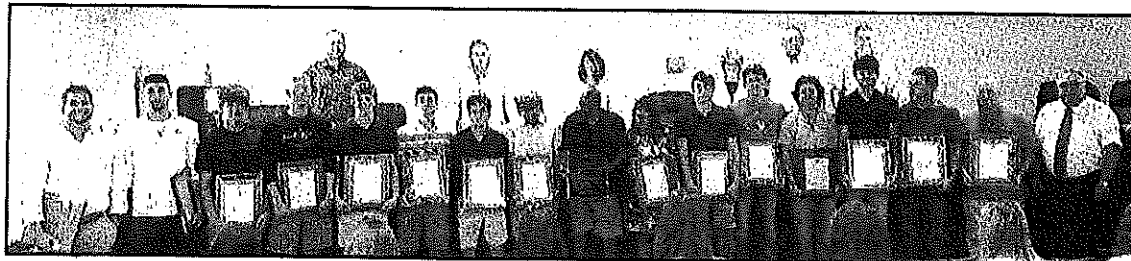

*11 - Players  
3 - Coaches*

**LEBANON HIGH SCHOOL  
2021 GROUP 2A BASEBALL STATE CHAMPIONS**

\*Members of the 2020-2021 Lebanon High School Virginia High School League State Championship Baseball Team.

**PLAYERS**

**Hunter Hertig**

Brian & Tracy Hertig  
109 Clinchview Circle  
Lebanon VA 24266

**Zach Hertig**

Brian & Tracy Hertig  
109 Clinchview Circle  
Lebanon VA 24266

**Nick Belcher**

David & Regina Belcher  
671 Oak Circle Drive  
Rosedale VA 24280

**Sage Potts**

Ryan & Meagan Potts  
413 Highland Drive  
Lebanon VA 24266

**Anthony Houchins**

Brian & Tamera Houchins  
1272 Pioneer Drive  
Lebanon VA 24266

**Preston Steele**

Eric & Lindsay Steele  
375 Windy Hill Circle  
Lebanon VA 24266

**Equipment Manager**

**Paul Hess**

P O Box 2543

Lebanon VA 24266



**LEBANON HIGH SCHOOL  
2021 VARSITY SOFTBALL TEAM**

*13 players  
1 Head Coach  
3 Asst. Coaches*

\*Members of the Lebanon High School 2021 Varsity Softball Team.

**Haley Finney**

Nathan & Melanie Finney  
P O Box 1870  
Lebanon VA 24266

**Maggie Lampkin**

Brandon & Farrah Lampkin  
181 Forest Brook Road  
Lebanon VA 24266

**Alexis Horne**

Josh & LeAnn Horne  
22721 Osprey Rd.  
Bristol VA 24292

**Tatum Dye**

Josh & Jody Miller  
1837 East Cross Roads  
Lebanon VA 24266

**Morgan Varney**

Glen & Melinda Varney  
164 Oak Hill Lane  
Rosedale VA 24280

**Adrienne Morrison**

Jeff & Angela Morrison  
P O Box 775  
2747 State Route North 71  
Lebanon VA 24266

## **Head Coach**

### **Dennis Price**

503 Warner Subdivision Road

Lebanon VA 24266

## **Assistant Coaches**

### **Sam Jones**

445 Donald C. Moore Drive

Lebanon VA 24266

### **Shelia Adams**

2407 Carterton Rd.

Lebanon VA 24266

### **Lynette Compton**

P O Box 227

Rosedale VA 24280

*Stream Sweepers*  
Clinch River 2021 Project

In Recognition

of

Service and Dedication to the Waterways in Russell County

1,095

Tires Removed



Awarded by

*Rebecca J. Dye*

CHAIR

Russell County Board of Supervisors





## StreamSweepers - Clinch River Project

August 27 at 3:39 PM · 🌐



Another day, another tire! Yesterday the crew was able to remove 68 tires despite diminishing water levels. **This puts us at 1,095 tires removed this year breaking last year's record of 1,077!** This wouldn't be possible without everyone's support and our sponsors!











DISCO

DISCOVERY 156

JOURNEY 156

Mad River Canoe





**Board of Supervisors**  
137 Highland Drive  
Lebanon, VA 24266

Action Item  
Presenters - Chairperson

**Meeting: 9/7/21 6:00 PM**

---

## **Public Hearing**

### **1. Alternative Public Educational Programs – School Choice**

**Staff Recommendation:**

Board Discretion.

**Suggested Motion:**

Board Discretion.

**ATTACHMENTS:**

- Various

# Russell County Virginia

“The Heart of Southwest Virginia”

Oris Christian  
At-Large

Lou Ann Wallace  
District 2

Carl Rhea  
District 3

Rebecca Dye, Chairperson  
District 6

Tim Lovelace, Vice-Chairman  
District 1

David Eaton  
District 4

Steve Breeding  
District 5

Lonzo Lester  
County Administrator

---

## **PUBLIC NOTICE**

The Russell County Board of Supervisors will conduct a **Public Hearing** on Tuesday, September 7, 2021, at 6:00 p.m. to hear comments concerning “**Public Interest Concerning Alternative Public School Educational Programs**”.

The Public Hearing will be held in the **Russell County Conference Room** at the Russell County Governmental Center, 133 Highland Drive, Lebanon, Virginia during the regular monthly meeting on September 7, 2021.

**BY ORDER OF THE  
RUSSELL COUNTY BOARD OF SUPERVISORS**

Russell County Government Center

137 Highland Drive · Lebanon, Virginia 24266 · (276) 889-8000 · Fax (276) 889-8011

[www.russellcountyva.us](http://www.russellcountyva.us)





**Board of Supervisors**  
137 Highland Drive  
Lebanon, VA 24266

Action Item A-1  
Presenter: Chairperson

**Meeting: 9/7/21 6:00 PM**

---

## Approval of Minutes

Request approval of the minutes from the following meeting:

- **Unapproved minutes of August 2, 2021**

### STAFF RECOMMENDATION(s):

Board discretion

### SUGGESTED MOTION(s):

Motion to approve Board Minutes.

### ATTACHMENTS:

- Board Minutes

August 02, 2021

The regular monthly meeting of the Russell County Board of Supervisors was held on Monday, August 02, 2021 beginning with Executive (closed) Session at 5:00 pm followed by the regular meeting at 6:00 pm at the Russell County Government Center in Lebanon, Virginia.

The Clerk called the meeting to order.

**EXECUTIVE (CLOSED) SESSION**

Motion made by Steve Breeding, second David Eaton and duly approved by the Board of Supervisors to enter into Executive (closed) Session to discuss legal matters pursuant to Section 2.2-3711(a)(1)(7)(8) – Legal Discussions concerning Personnel and Contractual Matters.

The vote was:

Aye: Steve Breeding, David Eaton, Tim Lovelace, Lou Wallace, Carl Rhea, Rebecca Dye and Oris Christian

Nay: None

**APPROVAL TO RETURN TO REGULAR SESSION**

Motion made by Steve Breeding, second David Eaton and duly approved by the Board of Supervisors to return to regular session.

The vote was:

Aye: Steve Breeding, David Eaton, Tim Lovelace, Lou Wallace, Carl Rhea, Rebecca Dye and Oris Christian

Nay: None

**CERTIFICATION OF CLOSED SESSION**

Pursuant to § 2.2-3712(D) of the Code of Virginia 1950, as amended each member of the Board of Supervisors upon the Roll Call certifies that to the best of their knowledge (i) only public business matters lawfully exempted from the open meeting requirements under the Virginia Freedom of

Information Act and (ii) only such public business matters that were identified in the motion(s) by which the closed meeting was convened were heard, discussed, or considered in the meeting by the Board of Supervisors.

Any member of the Board of Supervisors who believes that there was a departure from the requirements of clauses (i) and (ii) above shall so state prior to the vote, indicating the substance of the departure that, in his or her judgment, has taken place.

Are there any who believe a departure has taken place? Seeing none, if you agree that the matters heard, discussed, or considered during the closed meeting were pursuant only to the motion(s) by which the closed meeting was convened, please signify by saying aye or yes.

Tim Lovelace – AYE

Lou Wallace – AYE

Carl Rhea – AYE

David Eaton – AYE

Rebecca Dye - AYE  
Steve Breeding – AYE  
Oris Christian – AYE

Invocation by Chair Rebecca Dye, followed by the Pledge of Allegiance to the Flag.

#### **APPROVAL OF THE AGENDA**

Motion made by Steve Breeding, second Carl Rhea and duly approved by the Board of Supervisors to approve the agenda as presented.

The vote was:

Aye: Steve Breeding, Carl Rhea, Tim Lovelace, David Eaton, Lou Wallace, Rebecca Dye and Oris Christian  
Nay: None

#### **PUBLIC HEARING HELD ON THE CLEVELAND SCHOOL PROPERTY**

Pursuant to being advertised in a local newspaper for (2) two consecutive weeks, a public hearing was held on the transfer of the Cleveland School Property to the Russell County Industrial Development Authority. The Chair opened the public hearing to comments, hearing none the public hearing was closed.

#### **PUBLIC HEARING HELD ON THE GIVENS SCHOOL LEASE**

Pursuant to being advertised in a local newspaper for (2) two consecutive weeks, a public hearing was held on the Givens School Lease. The Chair opened the public hearing to comments.

Brian Simms spoke in favor of the lease.

Hearing no other comments, the public hearing was closed.

#### **PUBLIC HEARING HELD ON VDOT RTE. 637 DISCONTINUED BRIDGE**

Pursuant to being advertised in a local newspaper for (2) two consecutive weeks, a public hearing was held on the VDOT Rte. 637 discontinued bridge prescriptive easement right-of-way – 30-foot width and 0.02 – mile length. The Chair opened the public hearing to comments, hearing none the public hearing was closed.

#### **Board Appointments**

#### **Advisory Committee**

Advisory committee appointments were as follows:

Tim Lovelace – no appointment

Carl Rhea – Jennifer Chumbley  
David Eaton – Lynn Hess  
Steve Breeding – Nate Kiser  
Oris Christian – no appointment  
Rebecca Dye – no appointment

#### **BOARD APPOINTMENTS TABLED**

Motion made by Steve Breeding, second David Eaton and duly approved by the Board of Supervisors to table all BOS appointments listed on the agenda.

The vote was:

Aye: Steve Breeding, David Eaton, Tim Lovelace, Lou Wallace, Carl Rhea, Rebecca Dye and Oris Christian  
Nay: None

#### **New Business**

#### **APPROVAL OF THE JULY 12, 2021 MINUTES**

Motion made by Lou Wallace, second David Eaton and duly approved by the Board of Supervisors to approve the July 12, 2021 minutes and dispense with the reading thereof.

The vote was:

Aye: Lou Wallace, David Eaton, Tim Lovelace, Steve Breeding, Rebecca Dye and Oris Christian  
Nay: None  
Abstain: Carl Rhea

#### **APPROVAL OF GENERAL COUNTY INVOICES**

Motion made by Steve Breeding, second Lou Wallace and duly approved by the Board of Supervisors to approve general county invoices in the amount of \$1,944,703.06 including recurring and withholdings.  
The vote was:

Aye: Lou Wallace, David Eaton, Tim Lovelace, Steve Breeding, Rebecca Dye and Oris Christian  
Nay: None  
Abstain: Carl Rhea

#### **Citizens Comment**

The Chair opened citizens comment period.

**Doro Martin**, Lebanon invited the Board to attend the 1<sup>st</sup> Annual Vet Fest to be held at the Russell County Fairgrounds on September 25th and 26th.

**Shawn Vance**, Castlewood stated that Star Ministries needs funds, and the board should consider this. He also stated that the tabling committee appointments was ridiculous and unnecessary.

**Michelle Vance**, Castlewood commented that county boards should alter meeting schedules to better accommodate citizens that work.

**Nate Kiser**, Lebanon commented that it had been 46 days since the Advisory Committee was approved. He thinks that it is inexcusable and ridiculous that no appointments have been made from four of the Board members.

The chairperson closed citizens comment period.

### **County Attorney Reports and Requests**

#### **APPROVAL OF THE RUSSELL COUNTY COURTHOUSE COMPREHENSIVE AGREEMENT**

Motion made by Steve Breeding, second Lou Wallace and duly approved by the Board of Supervisors to approve the Russell County Courthouse Comprehensive Agreement subject to county attorney final revisions and minor changes.

The vote was:

Aye: Steve Breeding, Lou Wallace, Carl Rhea, Tim Lovelace, David Eaton, Rebecca Dye and Oris Christian

Nay: None

#### **APPROVAL TO NEGOTIATE WITH THE PROJECT JONAH CONSTRUCTION & ENVIRONMENTAL INSPECTION SERVICE RFQ TOP RANKED FIRM**

Motion made by Steve Breeding, second Tim Lovelace and duly approved by the Board of Supervisors to approve the Project Jonah Construction and Environmental Inspection Service RFQ committee proposal pursuant to procurement to negotiate with the top ranked firm.

The vote was:

Aye: Steve Breeding, Tim Lovelace, Carl Rhea, David Eaton, Lou Wallace, Rebecca Dye and Oris Christian

Nay: None

#### **APPROVAL TO TRANSFER THE CLEVELAND SCHOOL PROPERTY TO THE RUSSELL COUNTY IDA**

Motion made by Steve Breeding, second Carl Rhea and duly approved by the Board of Supervisors to transfer the Cleveland School Property to the Russell County Industrial Authority.

The vote was:

Aye: Steve Breeding, Carl Rhea, Tim Lovelace, David Eaton, Lou Wallace, Rebecca Dye and Oris Christian

Nay: None

#### **APPROVAL OF THE GIVENS SCHOOL LEASE**

Motion made by David Eaton, second Steve Breeding and duly approved by the Board of Supervisors to approve the Givens School lease upon final legal review and/or changes by the County Attorney.

The vote was:

Aye: Steve Breeding, David Eaton, Tim Lovelace, Lou Wallace, Carl Rhea, Rebecca Dye and Oris Christian  
Nay: None

**APPROVAL OF A WAIVER TO ADMINISTER AN EXISTING SPLIT PRECINCT**

Motion made by Lou Wallace, second David Eaton and duly approved by the Board of Supervisors to approve a waiver to administer an existing split precinct as requested by the General Registrar.

The vote was:

Aye: Lou Wallace, David Eaton, Steve Breeding, Tim Lovelace, Carl Rhea, Rebecca Dye and Oris Christian  
Nay: None

**County Administrator Reports and Requests**

The Chair appointed Lou Wallace and Tim Lovelace to serve on the Voter Redistricting Steering Committee.

**APPROVAL TO ACCEPT THE BROWNFIELDS ASSISTANCE FUND GRANT**

Motion made by Lou Wallace, second Carl Rhea and duly approved by the Board of Supervisors to accept the Brownfields Assistance Fund Grant in the amount of \$50,000.

The vote was:

Aye: Lou Wallace, Carl Rhea, Tim Lovelace, David Eaton, Steve Breeding, Rebecca Dye and Oris Christian  
Nay: None

**APPROVAL TO ACCEPT THE VIRGINIA DEPT. OF FIRE PROGRAMS GRANT**

Motion made by David Eaton, second Lou Wallace and duly approved by the Board of Supervisors to accept the Virginia Department of Fire Programs Grant in the amount of \$90,786.

The vote was:

Aye: Lou Wallace, David Eaton, Steve Breeding, Tim Lovelace, Carl Rhea, Rebecca Dye and Oris Christian  
Nay: None

**APPROVAL TO PROCLAIM AUGUST 22 AS SPINAL MUSCULAR ATROPHY AWARENESS DAY**

Motion made by David Eaton, second Steve Breeding and duly approved by the Board of Supervisors to proclaim August 22, 2021 as Spinal Muscular Atrophy Awareness Day.

The vote was:

Aye: Steve Breeding, David Eaton, Tim Lovelace, Lou Wallace, Carl Rhea, Rebecca Dye and Oris Christian  
Nay: None

**PUBLIC HEARING TO BE HELD TO SOLICIT INPUT ON SCHOOL CHOICE**

Motion made by Steve Breeding, second David Eaton and duly approved by the Board of Supervisors to hold a public hearing to solicit input on school choice on September 07, 2021 at 6:00 pm.

The vote was:

Aye: Steve Breeding, David Eaton, Tim Lovelace, Lou Wallace, Carl Rhea, Rebecca Dye and Oris Christian  
Nay: None

**APPROVAL TO ADJOURN**

Motion made by David Eaton, second Carl Rhea and duly approved by the Board of Supervisors to adjourn and to hold the next monthly meeting on Tuesday, September 07, 2021 due to Labor Day.

The vote was:

Aye: Steve Breeding, David Eaton, Tim Lovelace, Lou Wallace, Carl Rhea, Rebecca Dye and Oris Christian  
Nay: None

---

Clerk of the Board

---

Chairperson



**Board of Supervisors**  
137 Highland Drive  
Lebanon, VA 24266

Action Item A-2  
Presenter: Chairperson

**Meeting: 9/7/21 6:00 PM**

---

## **Approval of Expenditures**

Request approval of the County's August 2021 Monthly Expenditures:

### **STAFF RECOMMENDATION(s):**

County's August 2021 Monthly Expenditures are in compliance with budget and operational services.

### **SUGGESTED MOTION(s):**

Motion to approve County's August 2021 Monthly Expenditures.

### **ATTACHMENTS:**

- August 2021 Monthly Expenditures



<u>DUE DATE</u>	<u>INV. DATE</u>	<u>VENDOR</u>	<u>INVOICE</u>	<u>CLASS</u>	<u>GROSS AMT.</u>	<u>NET AMOUNT</u>	<u>G/L ACCOUNT</u>	<u>P.O.#</u>
9/07/2021	7/23/2021	002615 A&A ENTERPRISES	72710		1,314.85	1,314.85	4100-031020-5410-	-
9/07/2021	8/12/2021	002615 A&A ENTERPRISES	72885		555.00	555.00	4100-031020-5410-	-
					1,869.85	1,869.85 *		
9/07/2021	8/26/2021	004568 ADDINGTON OIL C	115006		3,730.22	3,730.22	4100-042400-5408-	-
					3,730.22	3,730.22 *		
9/07/2021	8/11/2021	004879 ALEXANDER TRACT	08112021		1,749.98	1,749.98	4100-042400-5408-	-
					1,749.98	1,749.98 *		
9/07/2021	7/04/2021	003845 ALSCO	LROA1004274		69.01	69.01	4100-072010-3008-	-
9/07/2021	8/11/2021	003845 ALSCO	LROA1005111		35.48	35.48	4100-072010-3008-	-
9/07/2021	8/25/2021	003845 ALSCO	LROA1006878		35.48	35.48	4100-072010-3008-	-
					139.97	139.97 *		
9/07/2021	6/21/2021	002792 APPALACHIAN GRA	6328		123.00	123.00	4100-031020-5409-	-
					123.00	123.00 *		
9/07/2021	8/15/2021	000046 AT&T	08152021		47.70	47.70	4100-031020-5203-	-
9/07/2021	8/15/2021	000046 AT&T	08152021		47.20	47.20	4100-031020-5203-	-
					94.90	94.90 *		
9/07/2021	7/21/2021	004494 BENTLEY DISTRIB	340371		7.05	7.05	4100-012090-5401-	-
9/07/2021	7/21/2021	004494 BENTLEY DISTRIB	340371		7.05	7.05	4100-012130-5401-	-
9/07/2021	7/21/2021	004494 BENTLEY DISTRIB	340371		7.05	7.05	4100-034010-5401-	-
9/07/2021	7/21/2021	004494 BENTLEY DISTRIB	340371		7.05	7.05	4100-012010-5401-	-
9/07/2021	7/21/2021	004494 BENTLEY DISTRIB	340371		7.05	7.05	4100-035050-5401-	-
					35.25	35.25 *		
9/07/2021	8/07/2021	004675 BIZZACK CONSTRU	3015		140.32	140.32	4100-042400-5413-	-
					140.32	140.32 *		
9/07/2021	8/04/2021	000052 BLEVINS SEPTIC	35396		510.00	510.00	4100-042010-5413-	-
					510.00	510.00 *		
9/07/2021	7/29/2021	003773 BLUE WOLF SALES	HS1673356		111.58	111.58	4100-031020-5408-	-
					111.58	111.58 *		
9/07/2021	7/26/2021	003808 BMS DIRECT INC	152723		967.19	967.19	4100-012130-5802-	-
					967.19	967.19 *		
9/07/2021	9/10/2021	003898 CARD SERVICES C	09102021		1,388.72	1,388.72	4100-011010-5504-	-
					1,388.72	1,388.72 *		
9/07/2021	2/15/2021	004350 CENTRAL HYDRAUL	15693		2,162.79	2,162.79	4100-042400-5407-	-
9/07/2021	2/15/2021	004350 CENTRAL HYDRAUL	15694		705.40	705.40	4100-042400-5407-	-
9/07/2021	2/15/2021	004350 CENTRAL HYDRAUL	15695		1,069.98	1,069.98	4100-042400-5407-	-
9/07/2021	5/15/2021	004350 CENTRAL HYDRAUL	15696		378.50	378.50	4100-042400-5407-	-
9/07/2021	2/15/2021	004350 CENTRAL HYDRAUL	15697		320.00	320.00	4100-042400-5407-	-
9/07/2021	2/15/2021	004350 CENTRAL HYDRAUL	15705		240.00	240.00	4100-042400-5407-	-
					4,876.67	4,876.67 *		
9/07/2021	8/16/2021	004450 CINTAS CORPORAT	40916310		27.59	27.59	4100-043020-3008-	-
9/07/2021	8/02/2021	004450 CINTAS CORPORAT	4091631060		27.59	27.59	4100-043020-3008-	-
9/07/2021	8/09/2021	004450 CINTAS CORPORAT	4092282713		27.59	27.59	4100-043020-3008-	-
9/07/2021	8/12/2021	004450 CINTAS CORPORAT	4092720425		75.78	75.78	4100-043020-3008-	-
9/07/2021	8/12/2021	004450 CINTAS CORPORAT	4092728023		47.02	47.02	4100-043020-3008-	-
9/07/2021	8/12/2021	004450 CINTAS CORPORAT	4092728067		108.24	108.24	4100-043020-3008-	-
9/07/2021	8/12/2021	004450 CINTAS CORPORAT	4092728085		94.05	94.05	4100-043020-3008-	-
9/07/2021	8/12/2021	004450 CINTAS CORPORAT	4092728086		38.72	38.72	4100-043020-3008-	-
9/07/2021	8/12/2021	004450 CINTAS CORPORAT	4092728106		261.68	261.68	4100-043020-3008-	-
9/07/2021	8/19/2021	004450 CINTAS CORPORAT	4093468697		261.68	261.68	4100-043020-3008-	-
9/07/2021	8/19/2021	004450 CINTAS CORPORAT	4093468707		38.72	38.72	4100-043020-3008-	-
9/07/2021	8/19/2021	004450 CINTAS CORPORAT	4093468745		94.05	94.05	4100-043020-3008-	-
9/07/2021	8/19/2021	004450 CINTAS CORPORAT	4093468839		75.78	75.78	4100-043020-3008-	-
9/07/2021	9/19/2021	004450 CINTAS CORPORAT	4093468864		97.53	97.53	4100-043020-3008-	-
9/07/2021	8/23/2021	004450 CINTAS CORPORAT	4093610386		27.59	27.59	4100-043020-3008-	-
9/07/2021	8/30/2021	004450 CINTAS CORPORAT	4094249024		27.59	27.59	4100-043020-3008-	-

<u>DUE DATE</u>	<u>INV. DATE</u>	<u>VENDOR</u>	<u>INVOICE</u>	<u>CLASS</u>	<u>GROSS AMT.</u>	<u>NET AMOUNT</u>	<u>G/L ACCOUNT</u>	<u>P.O.#</u>
9/07/2021	8/05/2021	004450 CINTAS CORPORAT	4092025848		38.72	38.72	4100-043020-3008-	- -
9/07/2021	8/05/2021	004450 CINTAS CORPORAT	4092025901		94.05	94.05	4100-043020-3008-	- -
9/07/2021	8/05/2021	004450 CINTAS CORPORAT	4092025975		323.11	323.11	4100-043020-3008-	- -
9/07/2021	8/05/2021	004450 CINTAS CORPORAT	4092026262		97.53	97.53	4100-043020-3008-	- -
9/07/2021	8/05/2021	004450 CINTAS CORPORAT	4092026326		75.78	75.78	4100-043020-3008-	- -
9/07/2021	8/26/2021	004450 CINTAS CORPORAT	4094010311		47.02	47.02	4100-043020-3008-	- -
9/07/2021	8/26/2021	004450 CINTAS CORPORAT	4094010338		108.24	108.24	4100-043020-3008-	- -
9/07/2021	8/26/2021	004450 CINTAS CORPORAT	4094010377		38.72	38.72	4100-043020-3008-	- -
9/07/2021	8/26/2021	004450 CINTAS CORPORAT	4094010379		94.05	94.05	4100-043020-3008-	- -
9/07/2021	8/26/2021	004450 CINTAS CORPORAT	4094010442		261.68	261.68	4100-043020-3008-	- -
9/07/2021	8/26/2021	004450 CINTAS CORPORAT	4094010702		83.75	83.75	4100-043020-3008-	- -
					2,593.85	2,593.85 *		
9/07/2021	7/20/2021	003569 CLARK PRINT SHO	4401		710.80	710.80	4100-012090-5401-	- -
9/07/2021	8/12/2021	003569 CLARK PRINT SHO	4408		191.50	191.50	4100-012090-5401-	- -
					902.30	902.30 *		
9/07/2021	9/30/2021	000153 COMM OF THE REV DUES 2021-2022			290.00	290.00	4100-011010-5801-	- -
					290.00	290.00 *		
9/07/2021	7/29/2021	004406 COMMONWEALTH IN LE202100334			669.25	669.25	4100-031020-5409-	- -
					669.25	669.25 *		
9/07/2021	8/13/2021	004452 CRYSTAL SPRINGS	214682450813202		19.14	19.14	4100-022010-5401-	- -
					19.14	19.14 *		
9/07/2021	8/10/2021	000091 DOLI/BOILER SAF	954150209		40.00	40.00	4100-043020-5407-	- -
					40.00	40.00 *		
9/07/2021	6/25/2021	000198 DOMINION OFFICE	133575		17.94	17.94	4100-012130-5401-	- -
9/07/2021	8/09/2021	000198 DOMINION OFFICE	134135		21.90	21.90	4100-012010-5401-	- -
9/07/2021	7/30/2021	000198 DOMINION OFFICE	134357		61.98	61.98	4100-032050-5401-	- -
9/07/2021	8/03/2021	000198 DOMINION OFFICE	134695		59.99	59.99	4100-021010-5401-	- -
9/07/2021	8/03/2021	000198 DOMINION OFFICE	134758		135.00	135.00	4100-021060-5401-	- -
9/07/2021	8/03/2021	000198 DOMINION OFFICE	134781		191.60	191.60	4100-021060-5401-	- -
9/07/2021	8/06/2021	000198 DOMINION OFFICE	134853		260.00	260.00	4100-012300-7002-	- -
9/07/2021	8/06/2021	000198 DOMINION OFFICE	134854		139.21	139.21	4100-012010-5401-	- -
9/07/2021	8/06/2021	000198 DOMINION OFFICE	134876		114.00	114.00	4100-043020-5405-	- -
9/07/2021	8/18/2021	000198 DOMINION OFFICE	134943		119.97	119.97	4100-043020-5405-	- -
9/07/2021	8/10/2021	000198 DOMINION OFFICE	134944		81.99	81.99	4100-021060-5401-	- -
9/07/2021	8/18/2021	000198 DOMINION OFFICE	134989		79.98	79.98	4100-043020-5405-	- -
9/07/2021	8/13/2021	000198 DOMINION OFFICE	135078		11.95	11.95	4100-034010-5401-	- -
9/07/2021	8/18/2021	000198 DOMINION OFFICE	135225		85.80	85.80	4100-032050-5401-	- -
9/07/2021	8/20/2021	000198 DOMINION OFFICE	135344		336.00	336.00	4100-043020-5405-	- -
9/07/2021	6/14/2021	000198 DOMINION OFFICE	133312		100.99	100.99	4100-031020-5401-	- -
9/07/2021	6/22/2021	000198 DOMINION OFFICE	133472		359.69	359.69	4100-031020-5401-	- -
9/07/2021	6/25/2021	000198 DOMINION OFFICE	133578		61.12	61.12	4100-031020-5401-	- -
9/07/2021	7/06/2021	000198 DOMINION OFFICE	133795		39.90	39.90	4100-031020-5401-	- -
9/07/2021	7/13/2021	000198 DOMINION OFFICE	134006		117.98	117.98	4100-031020-5401-	- -
9/07/2021	7/16/2021	000198 DOMINION OFFICE	134136		83.79	83.79	4100-031020-5401-	- -
9/07/2021	7/16/2021	000198 DOMINION OFFICE	134215		1.39	1.39	4100-031020-5401-	- -
9/07/2021	7/22/2021	000198 DOMINION OFFICE	134307		129.40	129.40	4100-031020-5401-	- -
9/07/2021	7/28/2021	000198 DOMINION OFFICE	134535		81.74	81.74	4100-031020-5401-	- -
9/07/2021	7/30/2021	000198 DOMINION OFFICE	134592		2.99	2.99	4100-031020-5401-	- -
9/07/2021	8/06/2021	000198 DOMINION OFFICE	134849		86.40	86.40	4100-031020-5401-	- -
9/07/2021	8/06/2021	000198 DOMINION OFFICE	134850		221.39	221.39	4100-031020-5401-	- -
9/07/2021	8/10/2021	000198 DOMINION OFFICE	134938		141.00	141.00	4100-031020-5401-	- -
9/07/2021	8/16/2021	000198 DOMINION OFFICE	135212		167.45	167.45	4100-031020-5401-	- -
9/07/2021	8/17/2021	000198 DOMINION OFFICE	135213		27.05	27.05	4100-031020-5401-	- -
9/07/2021	8/20/2021	000198 DOMINION OFFICE	135322		31.54	31.54	4100-031020-5401-	- -
9/07/2021	7/27/2021	000198 DOMINION OFFICE	134471		92.91	92.91	4100-013020-5401-	- -

<u>DUE DATE</u>	<u>INV. DATE</u>	<u>VENDOR</u>	<u>INVOICE</u>	<u>CLASS</u>	<u>GROSS AMT.</u>	<u>NET AMOUNT</u>	<u>G/L ACCOUNT</u>	<u>P.O.#</u>
9/07/2021	8/03/2021	000198 DOMINION OFFICE	134782		48.40	48.40	4100-012100-5401-	- -
9/07/2021	8/06/2021	000198 DOMINION OFFICE	134852		46.74	46.74	4100-012090-5401-	- -
9/07/2021	8/18/2021	000198 DOMINION OFFICE	134852.1		30.60	30.60	4100-012090-5401-	- -
9/07/2021	8/17/2021	000198 DOMINION OFFICE	134941		26.55	26.55	4100-013010-5401-	- -
9/07/2021	8/17/2021	000198 DOMINION OFFICE	135110		495.00	495.00	4100-012090-5401-	- -
9/07/2021	8/17/2021	000198 DOMINION OFFICE	135173		22.47	22.47	4100-021060-5401-	- -
					4,133.80	4,133.80	*	
9/07/2021	7/31/2021	003938 DRAPER ADEN ASS	2021070375		2,822.70	2,822.70	4100-042010-3090-	- -
					2,822.70	2,822.70	*	
9/07/2021	8/04/2021	004666 ENTERPRISE FLEE	FBN4254572		16,486.69	16,486.69	4100-031020-5408-	- -
					16,486.69	16,486.69	*	
9/07/2021	8/24/2021	001445 FISHER AUTO PAR	397-268384		7.12	7.12	4100-031020-5408-	- -
9/07/2021	8/30/2021	001445 FISHER AUTO PAR	397-268580		69.18	69.18	4100-042400-3004-	- -
					76.30	76.30	*	
9/07/2021	7/22/2021	000239 FOOD CITY	172337		39.74	39.74	4100-031020-5409-	- -
					39.74	39.74	*	
9/07/2021	7/21/2021	000854 GALL'S, LLC	18640858		132.37	132.37	4100-031020-5409-	- -
9/07/2021	8/12/2021	000854 GALL'S, LLC	18803986		46.67	46.67	4100-031020-5409-	- -
9/07/2021	8/25/2021	000854 GALL'S, LLC	18902220		22.95	22.95	4100-031020-5409-	- -
					201.99	201.99	*	
9/07/2021	7/19/2021	004713 HESS CASSANDRA	07192021		22.80	22.80	4100-022020-5401-	- -
					22.80	22.80	*	
9/07/2021	7/30/2021	003237 HIGHLANDS GLASS	27642		280.00	280.00	4100-043020-5407-	- -
9/07/2021	8/04/2021	003237 HIGHLANDS GLASS	27676		145.00	145.00	4100-043020-5407-	- -
					425.00	425.00	*	
9/07/2021	8/12/2021	000309 HONAKER FLORIST	2913		55.00	55.00	4100-011010-5413-	- -
					55.00	55.00	*	
9/07/2021	8/25/2021	000308 HONAKER TIRE SE	202334		3,570.82	3,570.82	4100-042400-5408-	- -
					3,570.82	3,570.82	*	
9/07/2021	9/01/2021	002725 ID NETWORKS IDE	248150		2,925.00	2,925.00	4100-031020-3005-	- -
					2,925.00	2,925.00	*	
9/07/2021	7/23/2021	003866 INNOVATIVE TECH	2887		412.50	412.50	4100-031020-3005-	- -
9/07/2021	8/13/2021	003866 INNOVATIVE TECH	2915		2,735.00	2,735.00	4100-031020-3005-	- -
9/07/2021	8/26/2021	003866 INNOVATIVE TECH	2927		562.50	562.50	4100-012300-7002-	- -
9/07/2021	8/26/2021	003866 INNOVATIVE TECH	2928		4,275.00	4,275.00	4100-012300-7002-	- -
9/07/2021	8/26/2021	003866 INNOVATIVE TECH	2929		37.50	37.50	4100-012300-7002-	- -
9/07/2021	8/26/2021	003866 INNOVATIVE TECH	2930		300.00	300.00	4100-012300-7002-	- -
9/07/2021	8/26/2021	003866 INNOVATIVE TECH	2931		75.00	75.00	4100-012300-7002-	- -
9/07/2021	8/26/2021	003866 INNOVATIVE TECH	2933		225.00	225.00	4100-012300-7002-	- -
9/07/2021	8/26/2021	003866 INNOVATIVE TECH	2935		837.50	837.50	4100-022010-5415-	- -
9/07/2021	8/26/2021	003866 INNOVATIVE TECH	2936		112.50	112.50	4100-072010-3001-	- -
9/07/2021	8/26/2021	003866 INNOVATIVE TECH	2941		150.00	150.00	4100-032050-3005-	- -
					9,722.50	9,722.50	*	
9/07/2021	7/25/2021	003587 JOHN DEERE FINA	07252021	1	186.01	186.01	4100-031020-5408-	- -
9/07/2021	7/02/2021	003587 JOHN DEERE FINA	1156514		13.99	13.99	4100-035010-5402-	- -
9/07/2021	7/06/2021	003587 JOHN DEERE FINA	1156730		67.74	67.74	4100-043020-5407-	- -
9/07/2021	7/14/2021	003587 JOHN DEERE FINA	1157916		48.97	48.97	4100-035010-5405-	- -
9/07/2021	7/21/2021	003587 JOHN DEERE FINA	1158710		26.99	26.99	4100-043020-5407-	- -
					343.70	343.70	*	
9/07/2021	8/19/2021	000353 KEGLEY SERVICE	35726		24.00	24.00	4100-031020-5408-	- -
9/07/2021	7/22/2021	000353 KEGLEY SERVICE	36457		143.17	143.17	4100-031020-5408-	- -
					167.17	167.17	*	
9/07/2021	7/27/2021	003245 KENDALL ELECTRI	S110556989.001		705.82	705.82	4100-043020-5407-	- -
9/07/2021	7/27/2021	003245 KENDALL ELECTRI	S110556989.002		941.38	941.38	4100-043020-5407-	- -
9/07/2021	8/17/2021	003245 KENDALL ELECTRI	S110629730.001		1,098.28	1,098.28	4100-043020-5407-	- -
					2,745.48	2,745.48	*	

<u>DUE DATE</u>	<u>INV.DATE</u>	<u>VENDOR</u>	<u>INVOICE</u>	<u>CLASS</u>	<u>GROSS AMT.</u>	<u>NET AMOUNT</u>	<u>G/L ACCOUNT</u>	<u>P.O.#</u>
9/07/2021	8/08/2021	002142 KESTNER MAX	1550		110.00	110.00	4100-031020-5409-	- -
					110.00	110.00 *		
9/07/2021	7/17/2021	002443 KING MOORE INC	4050		1,725.00	1,725.00	4100-032050-3002-	- -
					1,725.00	1,725.00 *		
9/07/2021	8/30/2021	000359 KWIK KAFE	3510-521437		73.00	73.00	4100-012010-5401-	- -
					73.00	73.00 *		
9/07/2021	9/20/2021	004880 LAWSONS TREE SE	2021097		6,200.00	6,200.00	4100-094010-8032-	- -
					6,200.00	6,200.00 *		
9/07/2021	7/01/2021	000367 LEBANON BLOCK &	435878		29.67	29.67	4100-043020-5407-	- -
9/07/2021	7/02/2021	000367 LEBANON BLOCK &	435967		1.99	1.99	4100-043020-5407-	- -
9/07/2021	7/06/2021	000367 LEBANON BLOCK &	436379		31.15	31.15	4100-043020-5407-	- -
9/07/2021	7/07/2021	000367 LEBANON BLOCK &	436499		14.14	14.14	4100-071040-5407-	- -
9/07/2021	7/09/2021	000367 LEBANON BLOCK &	436926		100.00	100.00	4100-094010-8029-	- -
9/07/2021	7/12/2021	000367 LEBANON BLOCK &	437147		2.70	2.70	4100-043020-5407-	- -
9/07/2021	7/12/2021	000367 LEBANON BLOCK &	437165		105.77	105.77	4100-042400-5407-	- -
9/07/2021	7/12/2021	000367 LEBANON BLOCK &	437339		5.90	5.90	4100-043020-5407-	- -
9/07/2021	7/13/2021	000367 LEBANON BLOCK &	437399		11.30	11.30	4100-043020-5407-	- -
9/07/2021	7/13/2021	000367 LEBANON BLOCK &	437403		1.30	1.30	4100-043020-5407-	- -
9/07/2021	7/14/2021	000367 LEBANON BLOCK &	437559		10.19	10.19	4100-042400-5407-	- -
9/07/2021	7/14/2021	000367 LEBANON BLOCK &	437560		128.24	128.24	4100-042400-5407-	- -
9/07/2021	7/14/2021	000367 LEBANON BLOCK &	437624		8.28	8.28	4100-043020-5407-	- -
9/07/2021	7/15/2021	000367 LEBANON BLOCK &	437806		35.63	35.63	4100-042400-5407-	- -
9/07/2021	7/15/2021	000367 LEBANON BLOCK &	437826		46.55	46.55	4100-035010-5405-	- -
9/07/2021	7/19/2021	000367 LEBANON BLOCK &	438187		9.79	9.79	4100-043020-5407-	- -
9/07/2021	7/23/2021	000367 LEBANON BLOCK &	438981		7.96	7.96	4100-071040-5407-	- -
9/07/2021	7/26/2021	000367 LEBANON BLOCK &	439183		5.78	5.78	4100-043020-5407-	- -
9/07/2021	7/26/2021	000367 LEBANON BLOCK &	439293		21.45	21.45	4100-042400-5407-	- -
9/07/2021	7/27/2021	000367 LEBANON BLOCK &	439397		23.89	23.89	4100-043020-5407-	- -
9/07/2021	7/27/2021	000367 LEBANON BLOCK &	439399		4.99	4.99	4100-043020-5407-	- -
9/07/2021	7/27/2021	000367 LEBANON BLOCK &	439432		28.57	28.57	4100-042400-5407-	- -
9/07/2021	7/27/2021	000367 LEBANON BLOCK &	439437		43.67	43.67	4100-042400-5407-	- -
9/07/2021	7/28/2021	000367 LEBANON BLOCK &	439584		12.30	12.30	4100-042400-5407-	- -
9/07/2021	7/28/2021	000367 LEBANON BLOCK &	439592		114.50	114.50	4100-042400-5407-	- -
9/07/2021	7/30/2021	000367 LEBANON BLOCK &	440003		5.64	5.64	4100-071040-5407-	- -
9/07/2021	9/09/2021	000367 LEBANON BLOCK &	441528		53.58	53.58	4100-031020-5401-	- -
9/07/2021	6/03/2021	000367 LEBANON BLOCK &	431556		99.00	99.00	4100-031020-5409-	- -
9/07/2021	6/17/2021	000367 LEBANON BLOCK &	433144		36.03	36.03	4100-031020-5409-	- -
9/07/2021	6/21/2021	000367 LEBANON BLOCK &	438631		24.11	24.11	4100-031020-5409-	- -
					824.07	824.07 *		
9/07/2021	8/06/2021	004877 LEISURE MEDIA 3	76856		3,135.00	3,135.00	4100-081040-3007-	- -
					3,135.00	3,135.00 *		
9/07/2021	8/23/2021	004881 LESTER MICHAEL	08232021		24.00	24.00	4100-042400-5401-	- -
					24.00	24.00 *		
9/07/2021	8/13/2021	004883 LOONEY ALYSSA L	08132021		97.23	97.23	4100-011010-5501-	- -
					97.23	97.23 *		
9/07/2021	8/13/2021	004255 MAGGARD SALES &	88083		806.76	806.76	4100-042010-3009-	- -
9/07/2021	8/20/2021	004255 MAGGARD SALES &	88379		245.39	245.39	4100-042010-3009-	- -
					1,052.15	1,052.15 *		
9/07/2021	6/21/2021	004876 MEYERCORD REVEN	244306		1,135.80	1,135.80	4100-012130-5402-	- -
					1,135.80	1,135.80 *		
9/07/2021	6/30/2021	004271 MOTOROLA SOLUTI	8281201439		44.47	44.47	4100-035050-5401-	- -
					44.47	44.47 *		
9/07/2021	5/04/2021	002181 NORFOLK SOUTHER	092014262		240.00	240.00	4100-043020-8001-	- -
					240.00	240.00 *		
9/07/2021	8/10/2021	003123 O'REILLY AUTO P	1943-423483		65.79	65.79	4100-031020-5408-	- -

<u>DUE DATE</u>	<u>INV. DATE</u>	<u>VENDOR</u>	<u>INVOICE</u>	<u>CLASS</u>	<u>GROSS AMT.</u>	<u>NET AMOUNT</u>	<u>G/L ACCOUNT</u>	<u>P.O.#</u>
9/07/2021	8/11/2021	003123 O'REILLY AUTO P	1943-423543		24.21	24.21	4100-031020-5408-	-
					90.00	90.00 *		
9/07/2021	8/01/2021	003041 OVERDRIVE INC	H-0078034	10	430.00	430.00	4100-073010-5411-	-
					430.00	430.00 *		
9/07/2021	8/15/2021	004595 POINT BROADBAND	3194759		100.65	100.65	4100-071040-5101-	-
					100.65	100.65 *		
9/07/2021	9/07/2021	001587 POSTMASTER	09072021		416.00	416.00	4100-013020-5201-	-
					416.00	416.00 *		
9/07/2021	7/08/2021	004420 PROBILLING & FU	261213606		51.60	51.60	4100-042400-5408-	-
					51.60	51.60 *		
9/07/2021	7/29/2021	004875 PUMP HOUSE SUPP	146529		231.48	231.48	4100-042400-5407-	-
					231.48	231.48 *		
9/07/2021	8/02/2021	004581 RFC COMPANY	213-S101005158.		186.95	186.95	4100-094010-8029-	-
					186.95	186.95 *		
9/07/2021	8/13/2021	002812 RICOH AMERICAS	35428017		158.59	158.59	4100-032050-3005-	-
9/07/2021	8/13/2021	002812 RICOH AMERICAS	35428136		44.83	44.83	4100-022010-5415-	-
9/07/2021	8/13/2021	002812 RICOH AMERICAS	35428474		166.90	166.90	4100-022010-3005-	-
9/07/2021	8/13/2021	002812 RICOH AMERICAS	35428548		184.90	184.90	4100-021020-3005-	-
9/07/2021	8/13/2021	002812 RICOH AMERICAS	35428602		84.03	84.03	4100-035010-5401-	-
9/07/2021	8/13/2021	002812 RICOH AMERICAS	35429003		253.60	253.60	4100-012010-3005-	-
9/07/2021	8/13/2021	002812 RICOH AMERICAS	35429160		100.56	100.56	4100-031020-3005-	-
9/07/2021	8/13/2021	002812 RICOH AMERICAS	35429164		116.15	116.15	4100-032050-3005-	-
9/07/2021	8/13/2021	002812 RICOH AMERICAS	354291763		188.84	188.84	4100-031020-3005-	-
9/07/2021	8/13/2021	002812 RICOH AMERICAS	35429233		111.06	111.06	4100-013020-3005-	-
9/07/2021	8/13/2021	002812 RICOH AMERICAS	35429369		96.97	96.97	4100-034010-5401-	-
					1,506.43	1,506.43 *		
9/07/2021	5/01/2021	002174 RUSSELL COUNTY	05012021		1,600.00	1,600.00	4100-071040-5407-	-
					1,600.00	1,600.00 *		
9/07/2021	9/01/2021	000663 RUSSELL COUNTY	09012021		7,740.00	7,740.00	4100-095010-9130-	-
					7,740.00	7,740.00 *		
9/07/2021	9/07/2021	004632 RUSSELL COUNTY	09072021		5,672.28	5,672.28	4100-082010-8025-	-
					5,672.28	5,672.28 *		
9/07/2021	8/16/2021	003455 SAFELITE AUTO G	01184-174892		470.66	470.66	4100-031020-5408-	-
					470.66	470.66 *		
9/07/2021	8/07/2021	003380 SHENTEL	08072021		239.44	239.44	4100-031020-5203-	-
9/07/2021	8/16/2021	003380 SHENTEL	08162021		118.23	118.23	4100-031020-5203-	-
9/07/2021	8/16/2021	003380 SHENTEL	08162021		239.44	239.44	4100-012010-5413-	-
9/07/2021	8/16/2021	003380 SHENTEL	08162021		239.44	239.44	4100-013020-5413-	-
					836.55	836.55 *		
9/07/2021	8/20/2021	004811 SIGNALSCAPE, IN	4229		679.99	679.99	4100-031020-5409-	-
					679.99	679.99 *		
9/07/2021	8/24/2021	002986 SOUTHWEST VA CR	08242021		200.00	200.00	4100-031020-5600-	-
					200.00	200.00 *		
9/07/2021	7/29/2021	001700 SOUTHWEST VA VE	07302021		1,775.82	1,775.82	4100-035010-5404-	-
9/07/2021	7/29/2021	001700 SOUTHWEST VA VE	137508		1,775.82	1,775.82	4100-035010-5404-	-
					3,551.64	3,551.64 *		<i>Delete</i>
9/07/2021	8/06/2021	004601 THE HOME DEPOT	633378377		110.18	110.18	4100-043020-5405-	-
					110.18	110.18 *		
9/07/2021	8/27/2021	000366 THE LEBANON NEW	08272021		34.00	34.00	4100-012130-5401-	-
9/07/2021	9/07/2021	000366 THE LEBANON NEW	09072021		34.00	34.00	4100-012130-5401-	-
9/07/2021	7/21/2021	000366 THE LEBANON NEW	138420		42.80	42.80	4100-011010-3007-	-
9/07/2021	7/21/2021	000366 THE LEBANON NEW	138421		53.50	53.50	4100-011010-3007-	-
9/07/2021	7/28/2021	000366 THE LEBANON NEW	138468		42.80	42.80	4100-011010-3007-	-
9/07/2021	7/28/2021	000366 THE LEBANON NEW	138469		53.50	53.50	4100-011010-3007-	-
					260.60	260.60 *		

<u>DUE DATE</u>	<u>INV. DATE</u>	<u>VENDOR</u>	<u>INVOICE</u>	<u>CLASS</u>	<u>GROSS AMT.</u>	<u>NET AMOUNT</u>	<u>G/L ACCOUNT</u>	<u>P.O.#</u>
9/07/2021	7/29/2021	001843 THE LIBRARY OF	1036831	10	188.91	188.91	4100-073010-3002-	- -
					188.91	188.91	*	
9/07/2021	7/29/2021	000977 TOP LINE ADVERT	7921		120.00	120.00	4100-031020-5410-	- -
					120.00	120.00	*	
9/07/2021	9/01/2021	000186 TREASURER OF VI	906124		1,176.00	1,176.00	4100-042010-3090-	- -
9/07/2021	9/01/2021	000186 TREASURER OF VI	906137		1,176.00	1,176.00	4100-042010-3090-	- -
					2,352.00	2,352.00	*	
9/07/2021	5/28/2021	002133 TREASURER OF VI	05282021		20.00	20.00	4100-035030-3001-	- -
					20.00	20.00	*	
9/07/2021	8/24/2021	000798 TRI CITY BLUEPR	08272021		1,225.00	1,225.00	4100-012300-7002-	- -
					1,225.00	1,225.00	*	
9/07/2021	6/21/2021	000706 TWO WAY RADIO I	104000959		845.00	845.00	4100-031020-7003-	- -
9/07/2021	7/14/2021	000706 TWO WAY RADIO I	3600000086-1		142.96	142.96	4100-031020-7003-	- -
9/07/2021	6/01/2021	000706 TWO WAY RADIO I	80003359		67.50	67.50	4100-031020-7003-	- -
9/07/2021	6/01/2021	000706 TWO WAY RADIO I	80003362		135.00	135.00	4100-031020-7003-	- -
					1,190.46	1,190.46	*	
9/07/2021	7/28/2021	002814 ULINE	136696912		722.06	722.06	4100-042400-5407-	- -
					722.06	722.06	*	
9/07/2021	6/24/2021	001959 VALECO	06242021		75.00	75.00	4100-012130-5801-	- -
					75.00	75.00	*	
9/07/2021	2/25/2021	003318 VIRGINIA TOURIS	INV00000007275		180.00	180.00	4100-081040-3007-	- -
					180.00	180.00	*	
9/07/2021	8/24/2021	003510 WAYNE MUSICK	7301		171.00	171.00	4100-022010-5415-	- -
					171.00	171.00	*	
9/07/2021	9/09/2021	004278 WELLS FARGO VEN	105292230		171.40	171.40	4100-012100-3005-	- -
9/07/2021	9/13/2021	004278 WELLS FARGO VEN	105301645		158.05	158.05	4100-031020-3005-	- -
					329.45	329.45	*	
9/07/2021	8/23/2021	004837 WEX ENTERPRISE	73548101		11,361.88	11,361.88	4100-031020-5408-	- -
					11,361.88	11,361.88	*	
9/07/2021	7/21/2021	000219 XPRESS LUBE	07212021		42.49	42.49	4100-031020-5408-	- -
9/07/2021	8/11/2021	000219 XPRESS LUBE	08112021		38.24	38.24	4100-031020-5408-	- -
					80.73	80.73	*	
		TOTAL FOR DUE DATE 9/07/2021			120,803.10	120,803.10		
		TOTAL DUE FOR FUND- 4100			120,803.10	120,803.10		

<u>DUE DATE</u>	<u>INV. DATE</u>	<u>VENDOR</u>	<u>INVOICE</u>	<u>CLASS</u>	<u>GROSS AMT.</u>	<u>NET AMOUNT</u>	<u>G/L ACCOUNT</u>	<u>P.O.#</u>
9/07/2021	8/19/2021	000198	DOMINION OFFICE 135299		832.52	832.52	4208-043020-5409-	- -
					832.52	832.52 *		
9/07/2021	8/19/2021	003901	LOU'S GLOVES 42705		2,847.00	2,847.00	4208-031020-5409-	- -
					2,847.00	2,847.00 *		
			TOTAL FOR DUE DATE 9/07/2021		3,679.52	3,679.52		
			TOTAL DUE FOR FUND- 4208		3,679.52	3,679.52		

<u>DUE DATE</u>	<u>INV. DATE</u>	<u>VENDOR</u>	<u>INVOICE</u>	<u>CLASS</u>	<u>GROSS AMT.</u>	<u>NET AMOUNT</u>	<u>G/L ACCOUNT</u>	<u>P.O.#</u>
9/07/2021	7/14/2021	004271	MOTOROLA SOLUTI 4066		4,259.29	4,259.29	4211-031020-5409-	- -
9/07/2021	7/14/2021	004271	MOTOROLA SOLUTI 4067		15,480.00	15,480.00	4211-031020-5409-	- -
					19,739.29	19,739.29 *		
			TOTAL FOR DUE DATE 9/07/2021		19,739.29	19,739.29		
			TOTAL DUE FOR FUND- 4211		19,739.29	19,739.29		



<u>DUE DATE</u>	<u>INV. DATE</u>	<u>VENDOR</u>	<u>INVOICE</u>	<u>CLASS</u>	<u>GROSS AMT.</u>	<u>NET AMOUNT</u>	<u>G/L ACCOUNT</u>	<u>P.O.#</u>
9/07/2021	7/27/2021	001337 BECKNER BOILER	8583		883.87	883.87	4839-083990-5407-	- -
					883.87	883.87	*	
9/07/2021	7/14/2021	000367 LEBANON BLOCK & 437604			115.28	115.28	4839-083990-5407-	- -
					115.28	115.28	*	
9/07/2021	7/21/2021	003374 MCMaster-CARR S 61987363			53.55	53.55	4839-083990-5407-	- -
					53.55	53.55	*	
		TOTAL FOR DUE DATE 9/07/2021			1,052.70	1,052.70		
		TOTAL DUE FOR FUND- 4839			1,052.70	1,052.70		
		NON-DIRECT DEPOSIT			145,274.61	145,274.61		
		DIRECT DEPOSIT			.00	.00		
		E-Payable Total			.00	.00		
		FINAL DUE			145,274.61	145,274.61		
						.00		



**Board of Supervisors**  
137 Highland Drive  
Lebanon, VA 24266

Action Item  
Presenter: Chairperson

**Meeting: 9/7/21 6:00 PM**

---

## Board Appointments

### 1. Committee Appointments for Board Consideration (Tabled).

#### County Advisory Committee

##### (1) Appointment Per Board Member

#### RC Planning Commission

Charles Edmonds	Four-Year Term	April 3, 2021
Roger Sword	Four-Year Term	December 31, 2020

#### Cumberland Plateau Economic Development Commission

Frank Horton	One-Year Term	June 30, 2021
Tony Lambert	One-Year Term	June 30, 2021
Ron Blankenship	One-Year Term	June 30, 2021
James Eaton, Jr.	One-Year Term	June 30, 2021

#### Dante Community Center

Jason Gullett	Two-Year Term	June 30, 2021
---------------	---------------	---------------

#### Russell County Library Board

Karen Herndon	Four-Year Term	June 30, 2021
Ann Monk	Four-Year Term	June 30, 2021
Judy Ashbrook	Four-Year Term	July 10, 2021

#### RC Highway & Safety Committee

Gary Dotson	Two-Year Term	July 1, 2021
Johnny Jessee	Two-Year Term	July 1, 2021
Steve Dye	Two-Year Term	July 1, 2021
Eugene Ferguson	Two-Year Term	July 1, 2021
Tony Maxfield	Two-Year Term	July 1, 2021

**Board of Supervisors**

137 Highland Drive  
Lebanon, VA 24266

Action Item  
Presenter: Chairperson

**Meeting: 9/7/21 6:00 PM**

<b>Mike O'Quinn</b>	<b>Two-Year Term</b>	<b>July 1, 2021</b>
<b>Barbara K. Cox</b>	<b>Two-Year Term</b>	<b>July 1, 2021</b>
<b>Henry E. Stinson, Jr.</b>	<b>Two-Year Term</b>	<b>July 1, 2021</b>
<b>Carl Rhea</b>	<b>Two-Year Term</b>	<b>July 1, 2021</b>
<b>Emory Altizer</b>	<b>Two-Year Term</b>	<b>July 1, 2021</b>

**Community Policy Management Team**

<b>Angela Farmer</b>	<b>Three-Year Term</b>	<b>August 3, 2021</b>
----------------------	------------------------	-----------------------

**Dante Community Center**

<b>Catherine Pratt</b>	<b>Two-Year Term</b>	<b>August 5, 2021</b>
------------------------	----------------------	-----------------------

**Southwest Community College Advisory Board**

<b>Lynn Keene</b>	<b>Four-Year Term</b>	<b>August 7, 2021</b>
<b>Gregory Brown</b>	<b>Four-Year Term</b>	<b>August 7, 2021</b>

**RC Industrial Development Authority (IDA)**

<b>Roger Sword</b>	<b>Four-Year Term</b>	<b>September 7, 2021</b>
<b>Scott Gilmer</b>	<b>Four-Year Term</b>	<b>September 7, 2021</b>

Name	District	Term	Term Ending	Phone Number
<b><u>Community Policy Management Team</u></b>				
Angela Farmer		Three Years	August 3, 2021	
<b><u>Dante Community Center</u></b>				
Catherine Pratt		Two Years	August 5, 2021	
<b><u>Southwest Community College Advisory Board</u></b>				
Lynn Keene		Four Years	August 7, 2021	
Gregory Brown		Four Years	August 7, 2021	
Name	District	Term	Term Ending	Phone Number
<b><u>Industrial Development Authority</u></b>				
Roger Sword		Four Years	September 5, 2021	
Scott Gilmer		Four Years	September 5, 2021	
<b><u>Drill Community Center</u></b>				
Michelle Tharp		Four Years	October 2, 2021	
<b><u>Oak Grove Community Center</u></b>				
Linda Cross		Two Years	October 7, 2021	
Frances Glovier		Two Years	October 7, 2021	
Rita "Charlene" Johnson		Two Years	October 7, 2021	
Tammy Perry		Two Years	October 7, 2021	
John Perry		Two Years	October 7, 2021	
Nancy Osborne		Two Years	October 7, 2021	
Peggy Kegley		Two Years	October 7, 2021	
<b><u>Russell County Planning Commission</u></b>				
Dustin Keith		Four Years	October 2, 2021	
Jack Compton		Four Years	October 2, 2021	



Name	District	Term	Term Ending	Phone Number
<b><u>Community Policy Management Team</u></b>				
Angela Farmer		Three Years	August 3, 2021	
<b><u>Dante Community Center</u></b>				
Catherine Pratt		Two Years	August 5, 2021	
<b><u>Southwest Community College Advisory Board</u></b>				
Lynn Keene		Four Years	August 7, 2021	
Gregory Brown		Four Years	August 7, 2021	
Name	District	Term	Term Ending	Phone Number
<b><u>Industrial Development Authority</u></b>				
Roger Sword		Four Years	September 5, 2021	
Scott Gilmer		Four Years	September 5, 2021	
Name	District	Term	Term Ending	Phone Number
<b><u>Drill Community Center</u></b>				
Michelle Tharp		Four Years	October 2, 2021	
<b><u>Oak Grove Community Center</u></b>				
Linda Cross		Two Years	October 7, 2021	
Frances Glovier		Two Years	October 7, 2021	
Rita "Charlene" Johnson		Two Years	October 7, 2021	
Tammy Perry		Two Years	October 7, 2021	
John Perry		Two Years	October 7, 2021	
Nancy Osborne		Two Years	October 7, 2021	
Peggy Kegley		Two Years	October 7, 2021	
<b><u>Russell County Planning Commission</u></b>				
Dustin Keith		Four Years	October 2, 2021	
Jack Compton		Four Years	October 2, 2021	



Name	Term	Term Ending	Phone Number
<b><u>Community Policy Management Team</u></b>			
Alice Meade	Three Years	November 5, 2021	
Lori Gates	Three Years	November 5, 2021	
<b><u>Russell County Planning Commission</u></b>			
Andy Smith	Four Years	November 6, 2021	
Name	Term	Term Ending	Phone Number
<b><u>Appalachian Juvenile Commission</u></b>			
Vicki Porter	Four Years	December 2, 2021	
<b><u>Cumberland Mountain Community Service Board</u></b>			
James Mounts	Three Years	December 31, 2021	
David Eaton	Three Years	December 31, 2021	
<b><u>Highway &amp; Safety Commission</u></b>			
Linda Cross	Two Years	December 31, 2021	
Name	Term	Term Ending	Phone Number
<b><u>People Inc. Development Financial Board</u></b>			
Alicia McGlothlin	Three Years	December 31, 2021	
Vicki Porter	Four Years	December 2, 2021	
<b><u>Cumberland Mountain Community Service Board</u></b>			
James Mounts	Three Years	December 31, 2021	
David Eaton	Three Years	December 31, 2021	
<b><u>Highway &amp; Safety Commission</u></b>			
Linda Cross	Two Years	December 31, 2021	



# Russell County Board of Supervisors Board Appointments

## Heart of Appalachia Tourism Development Authority

P.O. Box 1208, Lebanon, VA 24266

<b>BOARD MEMBERS:</b>	<b>APPOINTMENT TERM:</b>	<b>TERM EXPIRES:</b>
Heather Powers P.O. Box 1208 Lebanon, VA 24266 276-254-0014 heather.powers@russellcountyva.us	Two Years	September 10, 2022
Victoria Gent P.O. Box 2192 Lebanon, VA 24266 276-202-3073 victorialucindasmith@gmail.com	Two Years  District 1	September 10, 2022

**Boards Heather Powers was on:**

**HOA Tourism Development Authority**

**Health Coalition**



## **Items for August Agenda:**

Appointment of members to Advisory Committee "to discuss County and School issues relating to state mandates, budgeting, funding, etc.". As unanimously approved in the June 17, 2021 BOS meeting.

## **Proposed Amendment to Committee Selection process for one selection per BOS member per committee.**

I would like to make a motion to modify the selection process that was approved last month to allow a member of the Russell County Board of Supervisors to appoint a member from the entire citizenship of Russell County if, in the sole opinion of the appointing supervisor, a qualified candidate for that appointment cannot be found within that supervisor's voting district.

## **Methodology for future appointments by BOS until the One per One is achieved.**

The following is a potential method appointments as they come up.

If a supervisor has more than one representative from his district with different "term expiration" date and an appointment for one of those representatives comes up, the supervisor may do the following:

1. Reappoint that representative as the one for his/her district. In which case the remaining representatives from his/her district will come off the group when their terms expire and that appointment will go to the next supervisor who does not currently have a representative from his district on that group.
2. Pass that appointment to the next supervisor who does not currently have a representative from his/her district on that group. In which case the representative whose term has expired will come off that group.

The only remaining issue that needs to be discussed would be the order of appointment by any supervisors who do not currently have representatives from their district on a group. Perhaps a simple drawing for numbers 1 (first), 2 (second), 3 (third), etc.?

Groups impacted by this process are:

Highway and Safety Committee

Dist 1, 3 members (Dotson, O'Quinn, Cross, Lovelace)

Dist 2, 0 members

Dist 3, 4 members (Jessee, Maxfield, Cox, Rhea)

Dist 4, 2 members (Dye, Stinson)

Dist 5, 0 members

Dist 6, 2 members (Ferguson, Altizer)

At Lg, 0 members

Russell County Planning Commission

Dist 1, 1 member

Dist 2, 0 members

Dist 3, 3 members

Dist 4, 0 members

Dist 5, 0 members (Roger Sword resigned)

Dist 6, 2 members

At Lg, 0 members

(Wayne Young and Mark Mitchell, Districts unknown)

Russell County Library Board

Dist 1, 2 members (Herndon, Lyttle)

Dist 2, 1 members (Sargent)

Dist 3, 0 members

Dist 4, 2 members (Dye, VanDyke)

Dist 5, 4 members (Ashbrook, Davis, Monk, Breeding)

Dist 6, 0 members

At Lg, 0 members

Russell County Industrial Development Authority

Dist 1, 0 members

Dist 2, 1 members (Glass)

Dist 3, 0 members

Dist 4, 0 members

Dist 5, 4 members (Sword, Elliott, McFaddin, Lockhart)

Dist 6, 1 members (Christian)

At Lg, 1 members (Stamper)

Town 2, members (Dodi & Gilmer)

**From:** [kmcbride@russell.lib.va.us](mailto:kmcbride@russell.lib.va.us)  
**To:** [Lonzo Lester](#)  
**Cc:** [Vicki Porter](#)  
**Subject:** FW: Resignation from the Library of Trustees  
**Date:** Tuesday, August 3, 2021 9:16:31 AM

---

Lonzo,  
Sad news, but I had expected it. Were there any appointments last night?  
Kelly

-----Original Message-----

From: "Karen Herndon" <[cngrad@outlook.com](mailto:cngrad@outlook.com)>  
Sent: Monday, August 2, 2021 7:54pm  
To: "Kelly McBride" <[kmcbride@russell.lib.va.us](mailto:kmcbride@russell.lib.va.us)>  
Subject: Resignation from the Library of Trustees

Kelly and Library Board,

I am resigning from the Library Board of Trustees as of August 2, 2021. I have been promoted in my job and I just do not have the time and energy necessary to continue serving on the board.

It has been a pleasure to be a part of the Library Board and serve the citizens of Russell County. As you know, I was employed by the Russell County Public Library from 1995-2008 and later returned to serve on the Board. I have been involved in Library Board meetings for many years and I must say the current Board is the most conscientious of all I have known. This current Board not only consistently has a quorum present, but regularly has all members present which has not always been the case so this is to be commended. Keep up the good work.

I will continue to advocate for the library and its mission to serve the needs of Russell County.

*Sincerely,*  
*Karen*

Karen Herndon , CUA  
Director, Consulting Expert/ Section 508 Accessibility Team Lead  
CGI Federal

**From:** [Roger Sword](#)  
**To:** [rebtdy@gmail.com](mailto:rebtdy@gmail.com); [Steve Breeding](#); [david.eaton](#); [Louann Wallace](#); [Tim Lovelace](#); [Carl Rhea](#); [Lonzo Lester](#); [Ernest McFaddin](#)  
**Subject:** IDA Reappointment  
**Date:** Thursday, July 22, 2021 12:24:16 PM

---

I believe that my term of office as a member of the IDA is scheduled to end in September of this year. I have enjoyed my 14 years of service on that board and feel that I have contributed to the success we have seen. I would like to continue in that capacity, if it be the wishes of the Board of Supervisors.

The IDA presently consists of seven members appointed by you with an additional two members recommended by the Lebanon Town Council for a total membership of nine. Currently two of the sitting IDA members are fairly new in their tenure and I understand we will be likely getting another new replacement member from the Town Council in September. Experience and continuity are critical factors in the successful operation of the IDA and its mission.

The IDA is currently involved in several important projects and I would very much like to continue to be involved in their completion. I would appreciate your support for my reappointment. Thank you for your consideration.

Respectfully yours:

Roger Sword

--

This email has been checked for viruses by Avast antivirus software.  
<https://www.avast.com/antivirus>

Scott J. Gilmer  
258 Big Cedar Creek Rd.  
Lebanon, VA 24266  
276-701-2057

July 26, 2021

Russell Co. Board of Supervisors  
Lonzo Lester, County Administrator  
137 Highland Drive  
Lebanon, VA 24266

Dear Madam Chairman,

I would like to take this opportunity to thank you and the entire Board of Supervisors for your support and confidence in me serving on the Russell Co. IDA Board over the past four years. It has been a pleasure serving the citizens of our county. We have had many accomplishments together over this term and I am confident in the current board promoting Russell County for economic development and job creation. With that said, I would like to respectfully withdraw my name from consideration of reappointment in September of 2021. I look forward to assisting the IDA by any means possible in future projects within my capacity as councilman of the Town of Lebanon.

Sincerely,



Scott J. Gilmer



COUNTY OF RUSSELL, VIRGINIA

L Print Form 1

OFFICE USE ONLY:

COMMITTEE APPLICATION

Date Received: \_\_\_\_\_

Letter Sent: \_\_\_\_\_

Currently Serving On: \_\_\_\_\_

NAME: WATSON JOHN R MR.  
(Last) (First) (Middle Initial) (Mr., Mrs., Miss, Rank)

HOME ADDRESS: 2841 Mountain Road  
LEAK BUFF VA 24609 ljrwatson@gmail.com  
(Email Address)

TELEPHONE NUMBERS: 276 971 3576 276 971 3576 N/A  
(Home) (Business) (FAX)

PROFESSION/VOCATION: VIRGINIA DEPARTMENT OF TRANSPORTATION / MANAGER + ENGINEER

BOARDS/COMMISSIONS ON WHICH YOU WISH TO SERVE: Industrial Development Authority  
Planning Commission  
Public Service Authority  
(List no more than 3 -- in order of preference:)

OTHER INTERESTS: Outdoor Activities, Agriculture / Farming, Church youth  
outdoor adventure ministry

EDUCATION: H.S. diploma Lebanon High School, AAS degree Southwest VA Community  
College, AAS degree Southwest VA Community college, B.S degree Radford University, U.S. Army

JOB EXPERIENCE: VDOT Residency Administrator Ad Manager, deal w/ land  
development issues, help attract businesses to local area, work w/ IDA and BOS.

CIVIC OR SERVICE ORGANIZATION EXPERIENCE: Serve on Coal Severance boards in Russell,  
Buchanan, + several counties. Serve in civic groups, church youth ministry

ARE YOU CURRENTLY A MEMBER OF A RUSSELL COUNTY BOARD OR COMMISSION? NO

IF YES, PLEASE NAME: N/A

HAVE YOU PREVIOUSLY SERVED AS A MEMBER OF A RUSSELL COUNTY BOARD OR COMMISSION? YES

IF YES, PLEASE NAME: Russell Coal Haul Road / Coal Severance Tax

ARE YOU A REGISTERED VOTER? yes DISTRICT NUMBER: 6

## Loretta Vance

---

**From:** noreply@civicplus.com  
**Sent:** Monday, July 12, 2021 9:57 AM  
**To:** kaylin.ervin@russellcountyva.us; loretta.vance@russellcountyva.us  
**Subject:** Online Form Submittal: Board and Committee Application

### Board and Committee Application

Name	Donnie E Christian
Email Address	Dchristian501@yahoo.com
Address	PO Box 1917
City	Lebanon
State	VA
Zip Code	24266
Phone Number	276-254-0128
Fax Number	<i>Field not completed.</i>
Board/Committee on Which You Wish to Serve	Planning Commission Cumberland Plateau Economic Development Tourism
Other Interests	Serving the citizens of our region especially Russell Co with Good infrastructure, Great jobs & Wonderful Recreational opportunities.
Education	BS - Mining Engineering Completed majority of course work for dual BS in Civil Engineering.
Job Experience	35+ years of Engineered Planning & Design for Land Development & Infrastructure. Approx. 20 years with local Consulting Engineering firms and approx. 15 years with State Regulatory Agencies. Designed Subdivisions for Commercial & Residential Development - Prepared Plats.
Civic or Service Organization Experience	~4 years - VDOT Technical Advisor to RC Planning Commission 20+ years - Board of Director - RCPSA 1+ years - Industrial Development Authority



COUNTY OF RUSSELL, VIRGINIA

L Print Form... 1

OFFICE USE ONLY:

Date Received: \_\_\_\_\_

Letter Sent: \_\_\_\_\_

Currently Serving On: \_\_\_\_\_

NAME: Edmonds Charlie Mr  
(Last) (First) (Middle Initial) (Mr., Mrs., Miss, Rank)

HOME ADDRESS: 3907 Jesse's Mill Rd  
Cleveland, VA 24225 edmonds.cwe1@gmail.com  
(Email Address)

TELEPHONE NUMBERS: 276-494-6138 \_\_\_\_\_  
(Home) (Business) (FAX)

PROFESSION/VOCATION: Draftsman for US Gov., AEP Unit Supervisor, Engineer for Russell Mfg.

BOARDS/COMMISSIONS ON WHICH YOU WISH TO SERVE: RCPC

(List no more than 3 -- in order of preference:)

OTHER INTERESTS: Golf, fishing, woodworking, gardening

EDUCATION: High School Graduate, Technical School, Some college

JOB EXPERIENCE: Draftsman for US Gov., AEP Unit Supervisor, Engineer for Russell Mfg.

CIVIC OR SERVICE ORGANIZATION EXPERIENCE: Virginia Jaycees, Lions Club, Masonic Fraternity, Virginia Royal Arch, Virginia Eastern Star, Lebanon Baptist Church

ARE YOU CURRENTLY A MEMBER OF A RUSSELL COUNTY BOARD OR COMMISSION? \_\_\_\_\_

IF YES, PLEASE NAME: RCPC

HAVE YOU PREVIOUSLY SERVED AS A MEMBER OF A RUSSELL COUNTY BOARD OR COMMISSION? \_\_\_\_\_

IF YES, PLEASE NAME: RCPC

ARE YOU A REGISTERED VOTER? Yes DISTRICT NUMBER: 3





COUNTY OF RUSSELL, VIRGINIA

COMMITTEE APPLICATION

L Print Form...

OFFICE USE ONLY	
Date Received:	.....
Letter Sent:	JUN 19 2020
Currently Serving On:	Russell County IDA

Russell County IDA

NAME: McFaddin Luther E Mr  
(Last) (First) (Middle Initial) (Mr., Mrs., Miss, Rank)

HOME ADDRESS: 9438 Redbud Hwy, PO Box 1809  
Honaker VA 24260 ernie@  
McFaddinAssoc.com  
(Email Address)

TELEPHONE NUMBERS: 276-971-0690 276-873-5600 276-873-6788  
(Home) (Business) (FAX)

PROFESSION/VOCATION: Insurance Sales

BOARDS/COMMISSIONS ON WHICH YOU WISH TO SERVE: Russell County PSA  
(List no more than 3 -- in order of preference:) Russell County Planning Commission

OTHER INTERESTS: Volunteer service work, local and foreign mission work

EDUCATION: High school diploma and Business Administration courses

JOB EXPERIENCE: McFaddin + Associates 21 yrs, McFaddin Properties 15 years

CIVIC OR SERVICE ORGANIZATION EXPERIENCE: Helping Hands Ministries 15 yrs

ARE YOU CURRENTLY A MEMBER OF A RUSSELL COUNTY BOARD OR COMMISSION? IF Yes

YES, PLEASE NAME: Russell County IDA

HAVE YOU PREVIOUSLY SERVED AS A MEMBER OF A RUSSELL COUNTY BOARD OR COMMISSION? IF No

YES, PLEASE NAME: \_\_\_\_\_

ARE YOU A REGISTERED VOTER? Yes DISTRICT NUMBER: 3

**Loretta Vance**

---

**From:** noreply@civicplus.com  
**Sent:** Friday, November 20, 2020 10:24 AM  
**To:** kaylin.ervin@russellcountyva.us; loretta.vance@russellcountyva.us  
**Subject:** Online Form Submittal: Board and Committee Application

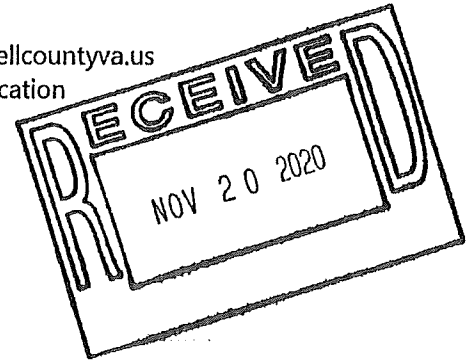

**Board and Committee Application**

**Name** Alita Ann Whited

**Email Address** alitawhited5@gmail.com

**Address** 85 Acre Lane

**City** Cedr Bfuff

**State** Russell

**Zip Code** 24609

**Phone Number** 276-971-4491

**Fax Number** *Field not completed.*

**Board/Committee on Which You Wish to Serve** Planning Commission

**Other Interests** *Field not completed.*

**Education** Associate Degree from SWCC  
Graduate Realtors Institute  
Multiple classes in Real Estate and Real Estate Appraisal

**Job Experience** 33 years as Real Estate Broker, Associate Broker and Agent  
(Licensed in all three categories at different times)  
13 years in Real Estate Appraisal (Certified Real Estate Appraiser)

**Civic or Service Organization Experience** Clinch River Kiwanis since 1989  
Richlands Garden Club  
Russell County Republican Committee

**Are you currently a member of a Russell County Board or Committee?** No

**If YES, please name:** *Field not completed.*

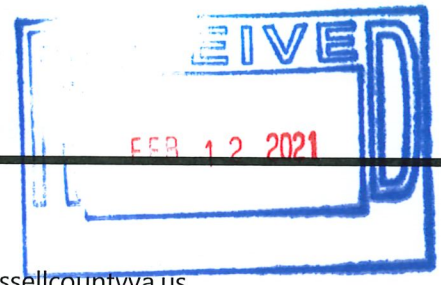

**Loretta Vance**

**From:** noreply@civicplus.com  
**Sent:** Friday, February 12, 2021 2:08 PM  
**To:** kaylin.ervin@russellcountyva.us; loretta.vance@russellcountyva.us  
**Subject:** Online Form Submittal: Board and Committee Application

## Board and Committee Application

Name	Robert Breimann
Email Address	rjb@streetlawfirm.com
Address	P.O. Box 2100
City	Grundy
State	VA
Zip Code	24614
Phone Number	2769352128
Fax Number	276-935-4162
Board/Committee on Which You Wish to Serve	Library Board
Other Interests	<i>Field not completed.</i>
Education	College; Graduate School; Law School
Job Experience	Partner -- Street Law Firm
Civic or Service Organization Experience	Coach youth league soccer, basketball and baseball. former Cub Scout Den leader.
Are you currently a member of a Russell County Board or Committee?	No
If YES, please name:	<i>Field not completed.</i>
Have you previously served as a member of a Russell County Board or Committee?	No
If YES, please name:	<i>Field not completed.</i>



COUNTY OF RUSSELL, VIRGINIA

COMMITTEE APPLICATION

Print Form

Submit by Email

OFFICE USE ONLY:

Date Received: \_\_\_\_\_

Letter Sent: \_\_\_\_\_

Currently Serving On : Library Board  
\_\_\_\_\_  
\_\_\_\_\_

NAME: Ashbrook \_\_\_\_\_ Judy \_\_\_\_\_ N \_\_\_\_\_ ~~Miss~~ Mrs. \_\_\_\_\_  
(Last) (First) (Middle Initial) (Mr., Mrs., Miss, Rank)

HOME ADDRESS: 389 Scenic Drive Lebanon, Virginia \_\_\_\_\_  
\_\_\_\_\_ jnashbrook@hotmail.com  
(Email Address)

TELEPHONE NUMBERS: (276) 889-1159 \_\_\_\_\_  
(Home) (Business) (FAX)

PROFESSION/VOCATION: School Teacher - Retired (37 Years) \_\_\_\_\_

BOARDS/COMMISSIONS ON WHICH YOU WISH TO SERVE: Russell County Library Board  
(List no more than 3 -- in order of preference:)  
\_\_\_\_\_  
\_\_\_\_\_

OTHER INTERESTS: Reading, Spending Time With Grandchildren, Traveling  
\_\_\_\_\_

EDUCATION: Master's Degree in Education (MEd) from University of Virginia, Bachelor of Science (Biology) King College  
Castlewood High School Graduate (1967)

JOB EXPERIENCE: Teacher - Russell County Public Schools - 37 years. Elementary and Middle School  
\_\_\_\_\_

CIVIC OR SERVICE ORGANIZATION EXPERIENCE: Daughter's of the American Revolution (DAR) Member with additional service  
to veterans.

ARE YOU CURRENTLY A MEMBER OF A RUSSELL COUNTY BOARD OR COMMISSION? Yes \_\_\_\_\_

IF YES, PLEASE NAME: Library Board \_\_\_\_\_

HAVE YOU PREVIOUSLY SERVED AS A MEMBER OF A RUSSELL COUNTY BOARD OR COMMISSION? \_\_\_\_\_

IF YES, PLEASE NAME: \_\_\_\_\_

ARE YOU A REGISTERED VOTER? Yes \_\_\_\_\_ DISTRICT NUMBER: 5 \_\_\_\_\_



COUNTY OF RUSSELL, VIRGINIA  
BOARD APPLICATION



Currently Serving On: \_\_\_\_\_

NAME: Monk Ann J Mrs.  
(Last) (First) (Middle Initial) (Mr., Mrs., Miss, Rank)

HOME ADDRESS: 509 Donald C. Moore Dr.  
Lebanon VA 24266 annjmonk@yahoo.com  
(Email Address)

TELEPHONE NUMBERS: 276-202-9972 \_\_\_\_\_  
(Home) (Business) (FAX)

PROFESSION/VOCATION: Retired

BOARD ON WHICH YOU WISH TO SERVE: Russell County Public Library  
(List no more than 3 -- in order of preference :)

OTHER INTERESTS: \_\_\_\_\_

EDUCATION: see resume

JOB EXPERIENCE: see resume

CIVIC OR SERVICE ORGANIZATION EXPERIENCE: \_\_\_\_\_

ARE YOU CURRENTLY A MEMBER OF A RUSSELL COUNTY BOARD OR COMMITTEE? yes  
IF YES, PLEASE NAME: Russell County Public Library

HAVE YOU PREVIOUSLY SERVED AS A MEMBER OF A RUSSELL COUNTY BOARD OR COMMITTEE? yes  
IF YES, PLEASE NAME: Russell County Tourism

ARE YOU A REGISTERED VOTER? yes DISTRICT NUMBER: 5th

## **ANN JACKSON MONK**

---

509 Donald C. Moore Drive  
Lebanon, Virginia 24266  
276-889-3786  
Email: [annjmonk@yahoo.com](mailto:annjmonk@yahoo.com)

### **SUMMARY OF QUALIFICATIONS**

- Offering a strong background of work experience in diverse environments and sound training.
- Knowledge of office procedures and equipment. Experienced in Microsoft Office, ProVal, and various other software programs.
- Accustomed to high volume, fast paced environments. Work effectively with persons of diverse backgrounds.
- Energetic and enthusiastic. Provide sustained effort for organizational and personal goals and objectives.
- Highly developed communication and interpersonal relation skills.
- Proven problem-solving abilities.
- Capable of handling multiple levels of tasks and responsibilities.

### **EDUCATION**

Alpha College of Real Estate - Newport News, Virginia  
Commonwealth of Virginia Real Estate License – January 1996 (not currently active)

Newport News Adult Education – Newport News, Virginia  
Classes in WordPerfect, Microsoft Windows, FoxPro

NASA Langley – Hampton, Virginia  
Course in Total Quality Management

Lebanon High School  
Lebanon, Virginia

### **EXPERIENCE**

August 2007 – June 2014

Russell County Public Library - Lebanon, Virginia

#### **Circulation Assistant**

Maintain close contact with library patrons at the circulation desk, checking materials in and out. Operate cash register while collecting payments for copies and printouts. Shelve returned books. Sign in patrons on public use computers.

June 2000 – April 2006

Assessor's Office City of Hampton, Virginia

**Technical Office Clerk**

Front office atmosphere having extensive work with the general public, real estate agents, surveyors, and attorneys in person as well as via telephone. Worked closely with other City departments - Treasurer, Commissioner of Revenue, Public Works, and Zoning as well as other departments. Entered deeds and wills into Assessor's Office public records, performed title search of property ownership, entered property splits and merges for City Tax Maps.

October 1996 – June 2000

City Manager's Office – City of Hampton, Virginia

**Staff Secretary/Receptionist**

Performed duties under the general supervision of the Director of Financial Policy. Extensive contact with the general public, city employees, elected officials, business executives, and representatives of municipal, state and federal governments. Provided telephone support for the Clerk of Council and Mayor's Office as well as the City Manager's Office and Assistant City Manger's Office. Reconciled credit card records for City Manager's Office. Planned catered events for Director of Financial Planning, arranged international travel for Mayor, members of City Council, City Manager and City Department Directors.

August 1991 – February 1996

Bionetics Corporation Hampton, Virginia

**Receptionist/Clerk/Switchboard Operator**

Received visitors and routed them to appropriate department/personnel. Extensive contact with local, state and federal elected officials, as well as NASA Langley personnel. Trained others in use of Meridan Telephone System. Provided clerical support as needed for Facilities Management, Marketing and Finance departments. Assisted with reorganizing Records Management Department. Operated various mail room equipment including Pitney Bowes mail meter, Fed Ex and UPS computer software. Reconciled company Fed Ex bills. Operated a thirty-six line switchboard and received messages for up to sixty employees.

**REFERENCES**

Available upon request.





**Board of Supervisors**  
137 Highland Drive  
Lebanon, VA 24266

Action Item  
Presenters - Attorney

**Meeting: 9/7/21 6:00 PM**

---

## County Attorney Reports

### 1. Project Jonah Interjurisdictional Agreement

**Staff Recommendation:**

Board Discretion.

**Suggested Motion:**

Discussion Only.

**ATTACHMENTS:**

- Various



**Board of Supervisors**  
137 Highland Drive  
Lebanon, VA 24266

Action Item C-1 – C-8  
Presenter: Administrator

**Meeting: 9/7/21      6:00 PM**

---

## **County Administrator Reports & Requests**

The County Administrator Reports & Request for September 2021:

### **REPORTS**

- 1. RC Sanitary Landfill – Leachate Storage Tank Operations.....C-1**
- 2. VDOT September 2021 BOS Update Report.....C-2**
- 3. COV Auditor of Public Accounts – Clerk of Circuit Court.....C-3**

### **REQUESTS**

- 4. VDOT Rte. 637 Discontinued Bridge & Prescriptive Easement.....C-4  
Right-of-Way – 30 ft. width & 0.02-mile length**
- 5. RC IDA AFID Grant – Project Brown.....C-5**
- 6. Supreme Court of VA Drug Treatment Court Docket Grant - \$90,000.....C-6**
- 7. Three Rivers Destination Center – Professional Consulting Services RFQ.....C-7**
- 8. VA Department of Criminal Justice Services Grant - \$70,000.....C-8**
- 9. RC Disposal Truck Surplus.....C-9**

### **STAFF RECOMMENDATION(s):**

Board Discretion.

# Russell County Landfill

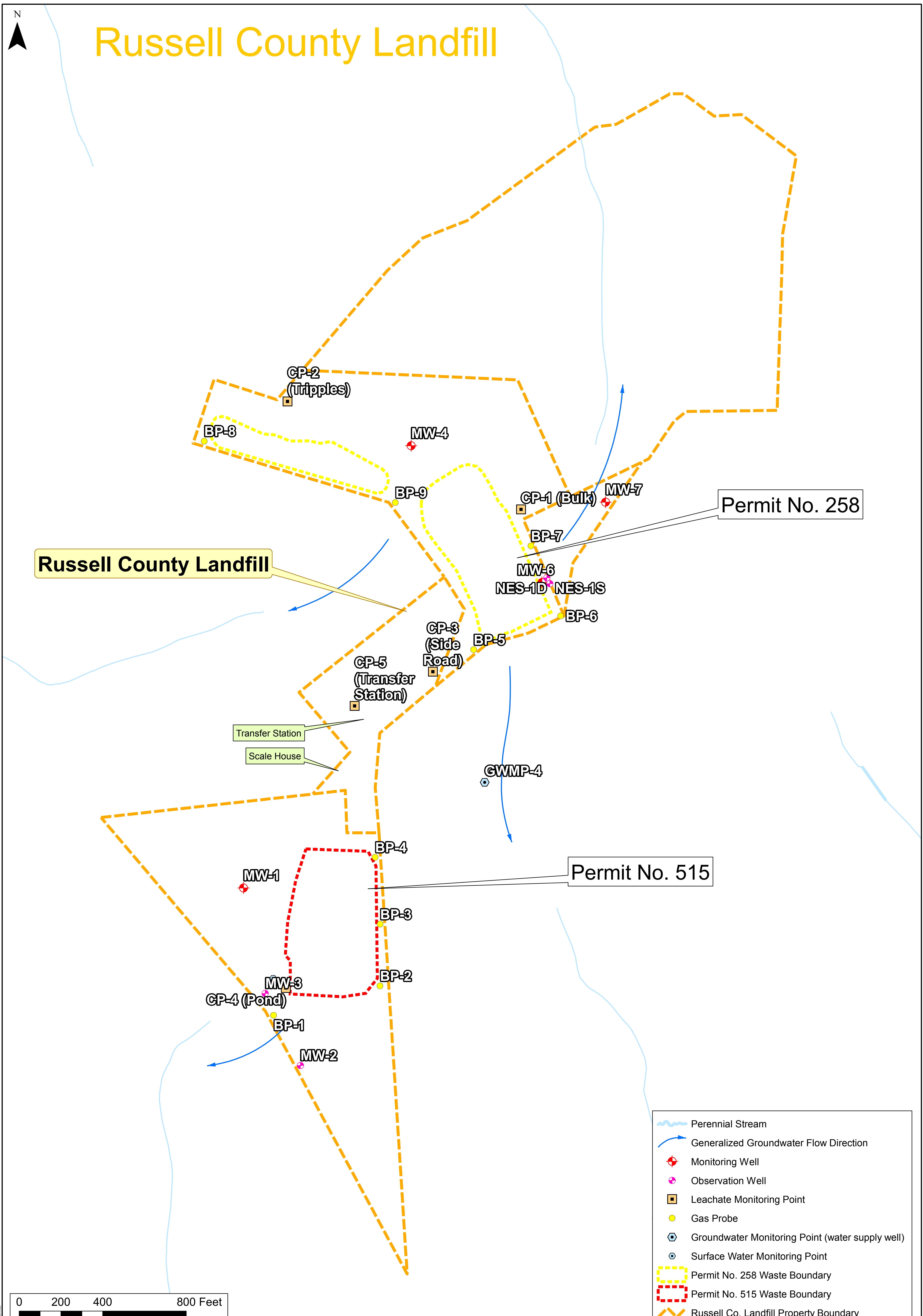

Russell County Landfill

Permit No. 258

Permit No. 515

- Perennial Stream
- Generalized Groundwater Flow Direction
- Monitoring Well
- Observation Well
- Leachate Monitoring Point
- Gas Probe
- Groundwater Monitoring Point (water supply well)
- Surface Water Monitoring Point
- Permit No. 258 Waste Boundary
- Permit No. 515 Waste Boundary
- Russell Co. Landfill Property Boundary

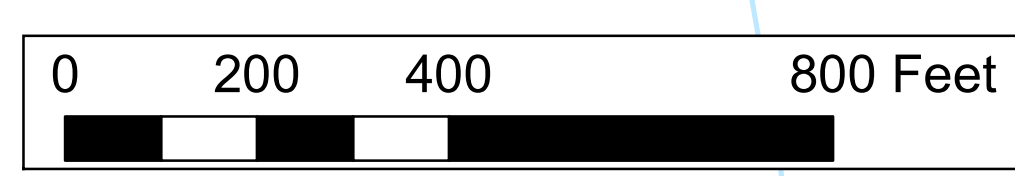

Aerial Imagery: Spring 2015 Copyright Commonwealth of Virginia, VGIN Online

Virginia Geographic Information Network (VGIN)

DESIGNED BY:	DM
DRAWN BY:	WMD
CHECKED BY:	LPK
SCALE:	1" = 200'
DATE:	11/14/2017
PROJECT NUMBER:	B13159B-01
FIGURE:	1 of 3

REVISIONS Aerial Photo Russell County Landfill, Permit Nos. 258 & 515 Russell County, Virginia	

**Draper Aden Associates**  
*Engineering • Surveying • Environmental Services*

2206 South Main Street Blacksburg, VA 24060 540-552-0444 Fax: 540-552-0291	Richmond, VA Charlottesville, VA Hampton Roads, VA	Raleigh, NC Fayetteville, NC Northern Virginia
--	--	--



# SOLID WASTE PERMIT NO. 515 RUSSELL COUNTY SANITARY LANDFILL

\* \* \*

RUSSELL COUNTY, VIRGINIA

DRAFT

### OWNER INFORMATION

RUSSELL COUNTY, VA  
SOLID WASTE  
137 HIGHLAND DRIVE  
LEBANON, VA 24266  
OFFICE PHONE: (276) 415-9102

LONZO LESTER  
COUNTY ADMINISTRATOR  
(276) 889-8000

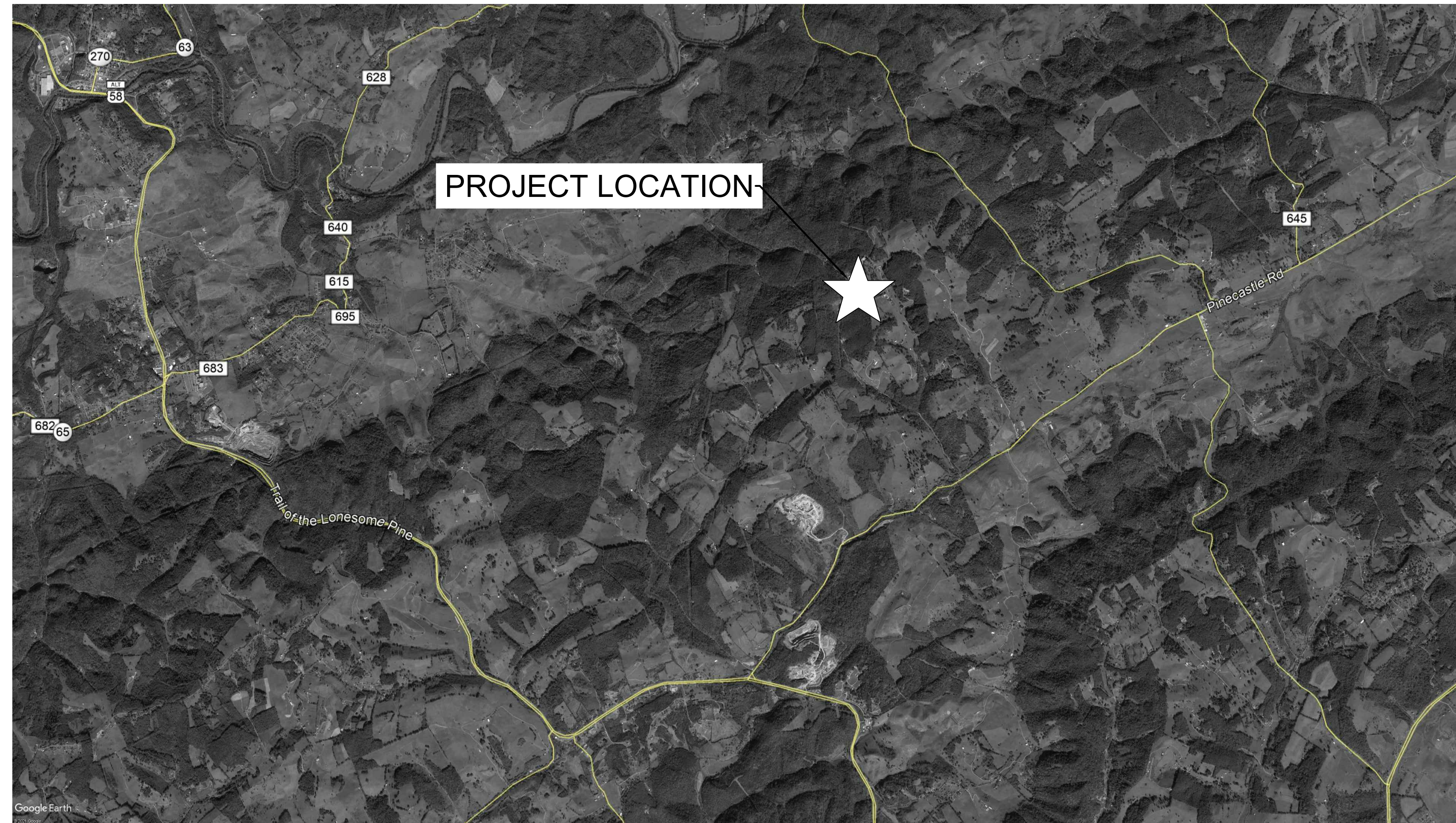

### DRAWING LIST

- SHEET 0 - COVER
- SHEET 1 - SITE PLAN
- SHEET 2 - PIPING SCHEMATIC
- SHEET 3 - DETAILS

**Draper Aden Associates**  
Engineering • Surveying • Environmental Services



2206 South Main Street  
Blair, VA 24060  
540-552-0444 Fax: 540-552-0291  
www.daa.com

- Raleigh, NC
- Fayetteville, NC
- Richmond, VA
- Charlottesville, VA
- Northern Virginia
- Hampton Roads, VA
- Virginia Beach, VA

SOLID WASTE PERMIT NO. 515  
RUSSELL COUNTY  
SANITARY LANDFILL  
RUSSELL COUNTY, VA

REVISIONS

NOTE: CONTRACTOR TO CONTACT MISS UTILITY (811) IN ADVANCE OF PLANNED WORK. ADVANCE TIME PERIOD SHALL BE IN ACCORDANCE WITH CURRENT MISS UTILITY GUIDELINES (www.missutilityofvirginia.com).



These documents, including drawings and specifications, were prepared by Draper Aden Associates, Consulting Engineers, pursuant to a contract by and between Draper Aden Associates and Prince George County with respect to the project described in said contract. Any reuse or modification of said documents (whether hard copy or electronic) without written verification or adaptation by Draper Aden Associates for the specific purpose intended will be at the sole risk of the individual or entity utilizing said documents, drawings and specifications and such use is without the authorization of Draper Aden Associates. Draper Aden Associates, Consulting Engineers, shall have no legal liability resulting from any and all claims, damages, losses, and expenses, including attorney's fees arising out of the unauthorized use of these documents, drawings, specifications, reports, and studies prepared as a result of the aforesaid contract.

### DRAPER ADEN ASSOCIATES REVIEW

THESE PLANS HAVE BEEN SUBJECTED TO TECHNICAL AND QUALITY REVIEWS BY:

ETHAN GARTIN, E.I.T.  
NAME: PRINTED SIGNATURE DATE 08/12/2021  
PROJECT DESIGNER

WILLIAM MASON-DEESE  
NAME: PRINTED SIGNATURE DATE 08/12/2021  
PROJECT MANAGER

STEVEN R. GANDY, PH.D., P.E.  
NAME: PRINTED SIGNATURE DATE 08/12/2021  
QUALITY REVIEWER

DESIGNED BY:	EWG
DRAWN BY:	EWG
CHECKED BY:	SG
SCALE:	NONE
DATE:	August 12, 2021
PROJECT NUMBER:	B13159B-01

0  
OF 3



DRAFT

**Draper Aden Associates**  
Engineering • Surveying • Environmental Services  
2206 South Main Street  
Blacksburg, VA 24060  
540-552-0444 Fax: 540-552-0291  
www.daa.com  
• Raleigh, NC  
• Fayetteville, NC  
• Northern Virginia  
• Richmond, VA  
• Charlottesville, VA  
• Hampton Roads, VA  
• Virginia Beach, VA

SOLID WASTE PERMIT NO. 515  
RUSSELL COUNTY  
SANITARY LANDFILL  
RUSSELL COUNTY, VA

REVISIONS

DESIGNED BY: EWG  
 DRAWN BY: EWG  
 CHECKED BY: SG  
 SCALE: 1/8" = 1'-0"  
 DATE: August 12, 2021  
 PROJECT NUMBER: B13159B-01

**NOTES:**

- LEACHATE TANKS NO. 1-3 SHALL HAVE SUBMERSIBLE PUMPS INSTALLED AND ASSOCIATES APPURTENANCES AS SELECTED BY THE OWNER AND IN ACCORDANCE WITH MANUFACTURER'S RECOMMENDATIONS
- PIPING SHALL INCLUDE ALL FITTINGS AND APPURTENANCES NECESSARY TO PROVIDE A WORKING PRODUCT

INSTALL FIVE (5) NEW 4,000 GALLON TANKS AND CONCRETE PAD

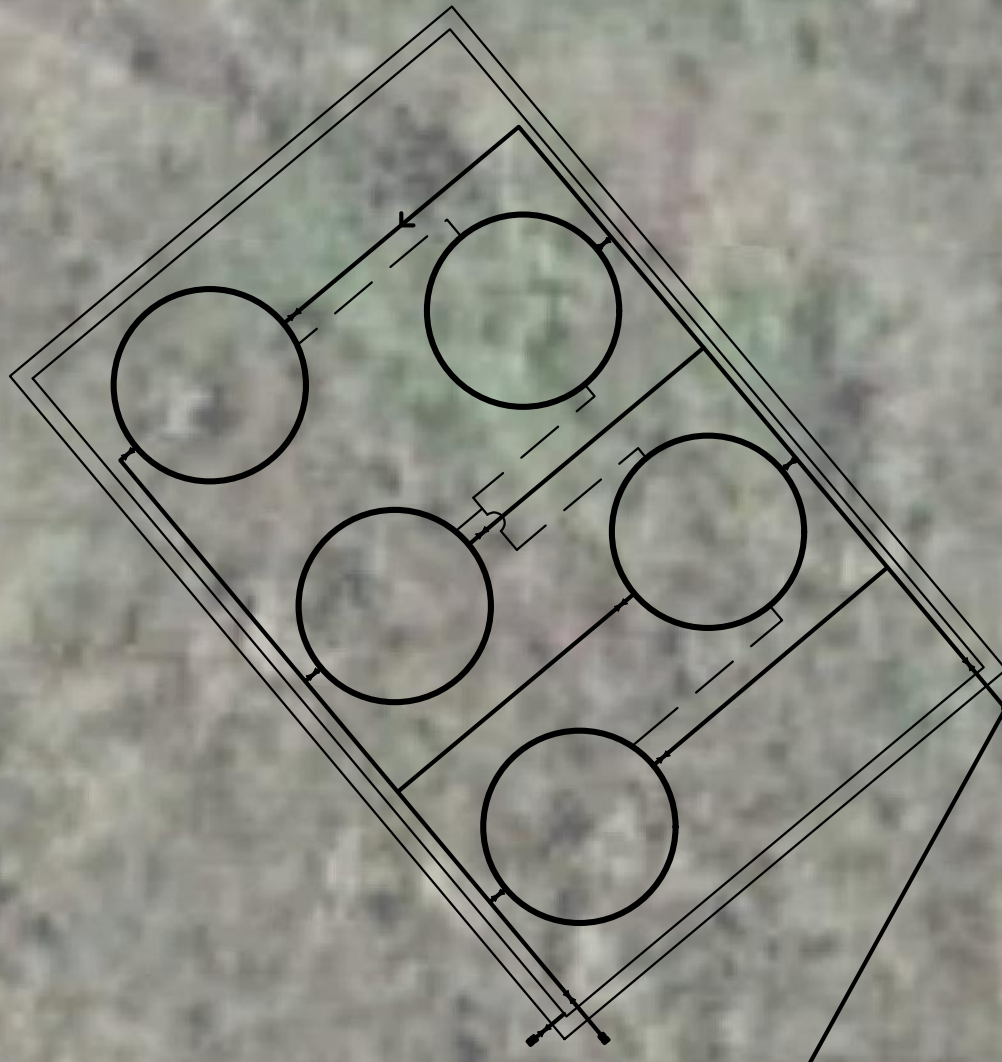

INSTALL 4" PVC SCH. 80 PVC PIPE WITH 18" COVER

INSTALL 4" GATE VALVE AND CHECK VALVE IN VALVE BOX AT GRADE

EXISTING LEACHATE TANK NO. 1 - 5,000 GALLONS

EXISTING LEACHATE TANK NO. 2 - 5,000 GALLONS

EXISTING LEACHATE TANK NO. 3 - 5,000 GALLONS

P:\B13159B\B13159B-01\DWG\B13159B-01 Project Drawings.dwg August 12, 2021 10:29:44 AM





DRAFT

Draper Aden Associates  
 Engineering • Surveying • Environmental Services



2206 South Main Street  
 Salisbury, VA 24060  
 540-552-0444 Fax: 540-552-0291  
 www.daa.com

SOLID WASTE PERMIT NO. 515  
 RUSSELL COUNTY  
 SANITARY LANDFILL  
 RUSSELL COUNTY, VA

REVISIONS

DESIGNED BY: EWG  
 DRAWN BY: EWG  
 CHECKED BY: SG  
 SCALE: AS SHOWN  
 DATE: August 12, 2021  
 PROJECT NUMBER: B13159B-01

3  
 OF 3

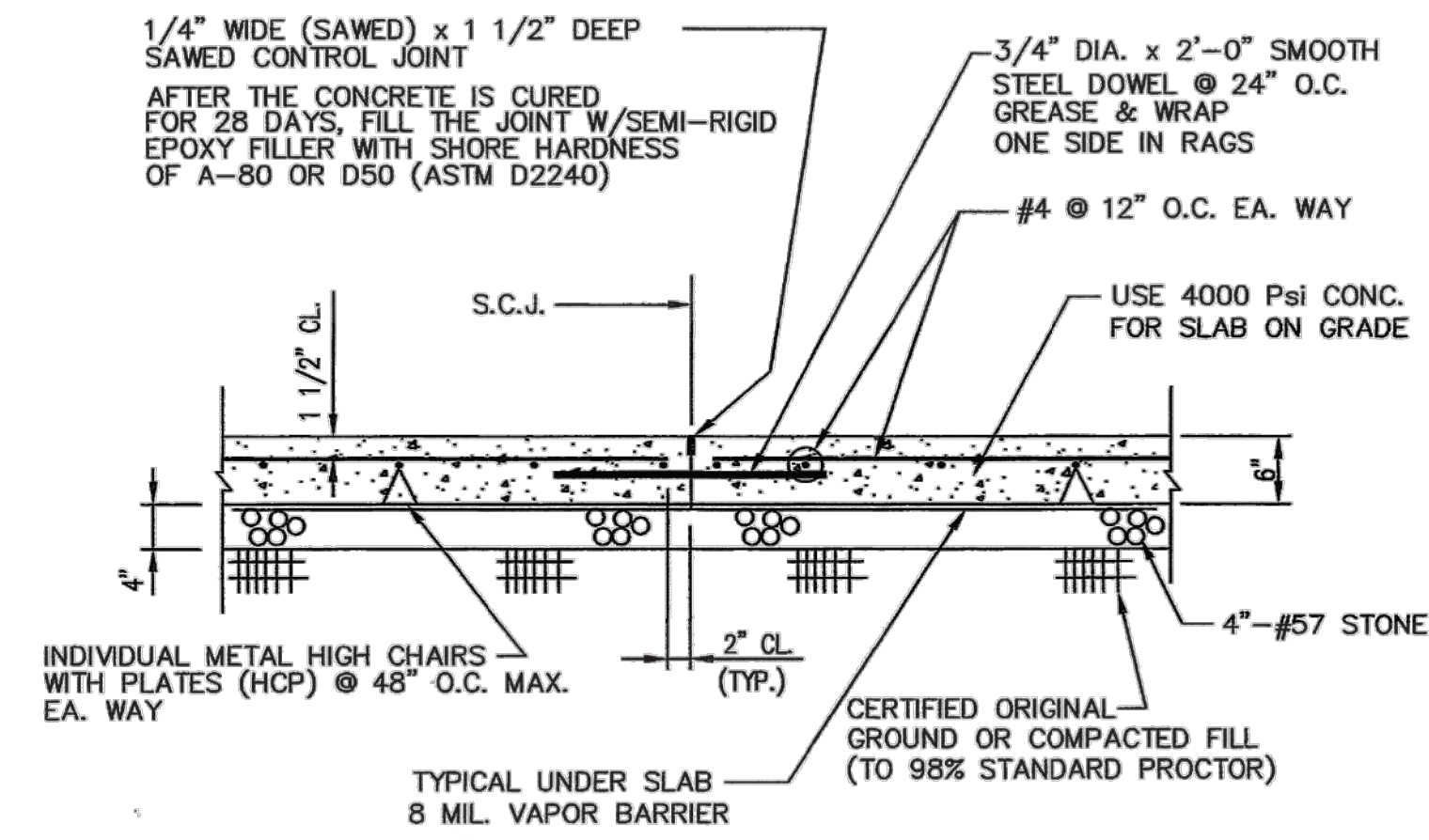

NOTE: 1) USE VAPOUR BARRIER UNDER SLAB

1 TYPICAL 6" SLAB DETAIL  
 S1 SCALE: 3/4" = 1'-0"

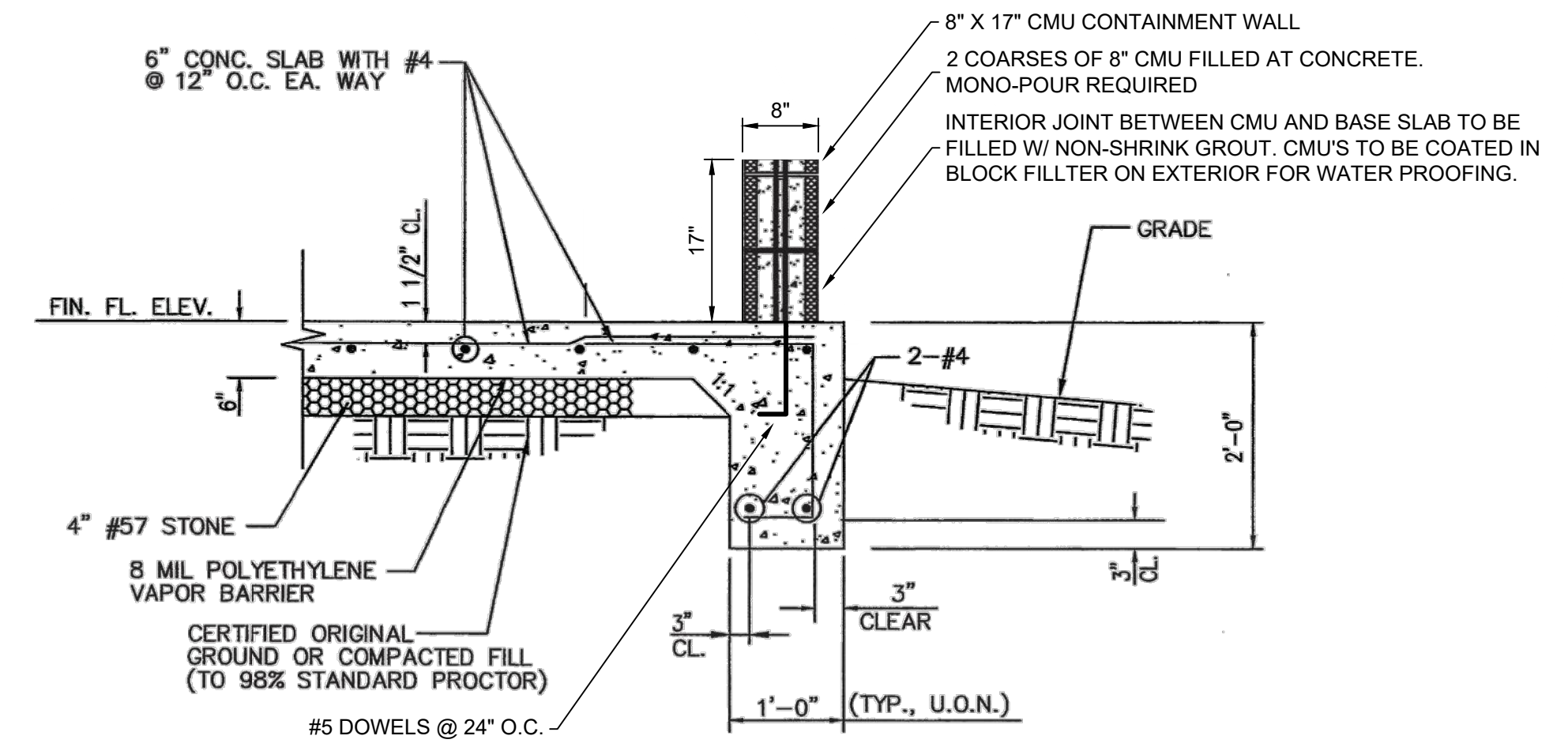

3 SECTION  
 S1 SCALE: 3/4" = 1'-0"

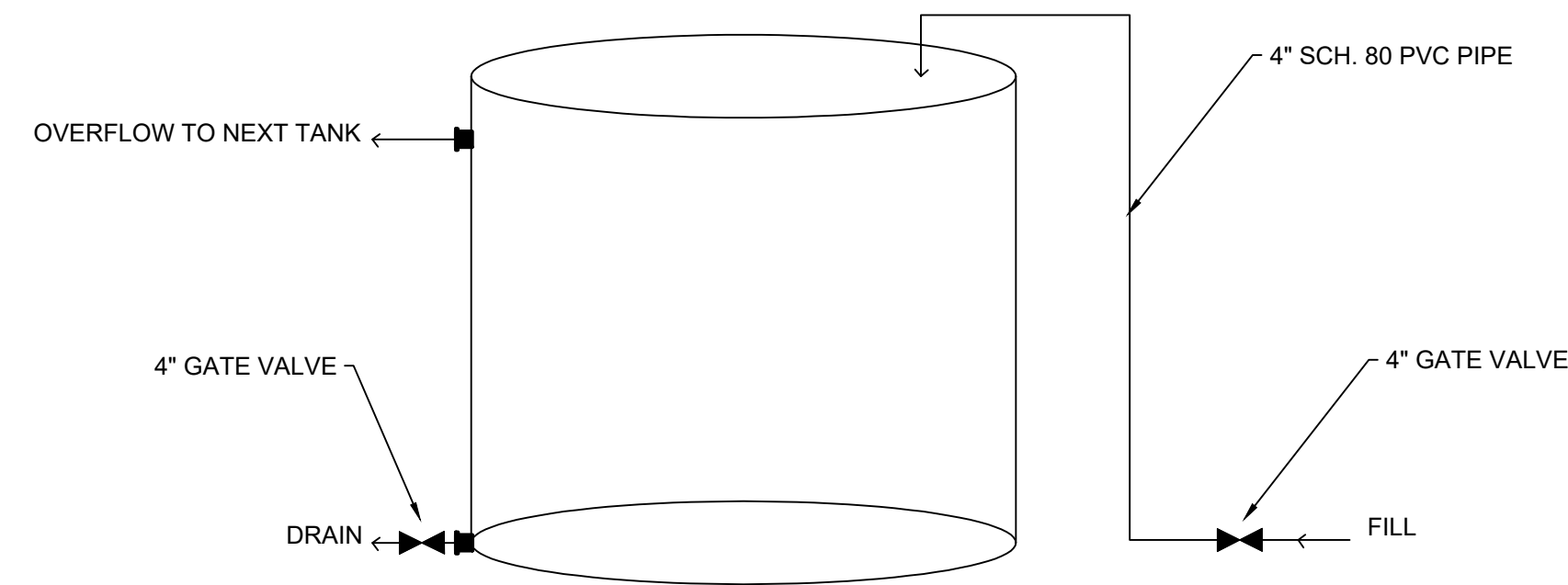

2 TANK SCHEMATIC  
 S1 SCALE: NOT TO SCALE

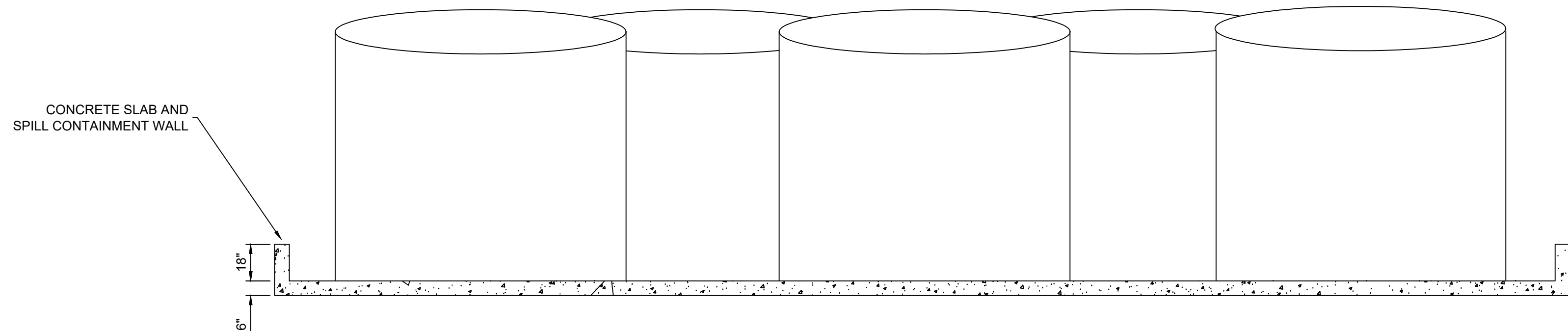

4 SPILL CONTAINMENT PROFILE  
 S1 SCALE: NOT TO SCALE



P:\B13100\B13159B-01\CAD\B13159B-01 POTENTIOMETRIC SURFACE MAY 2017.dwg Sep 20, 2018 3:34pm

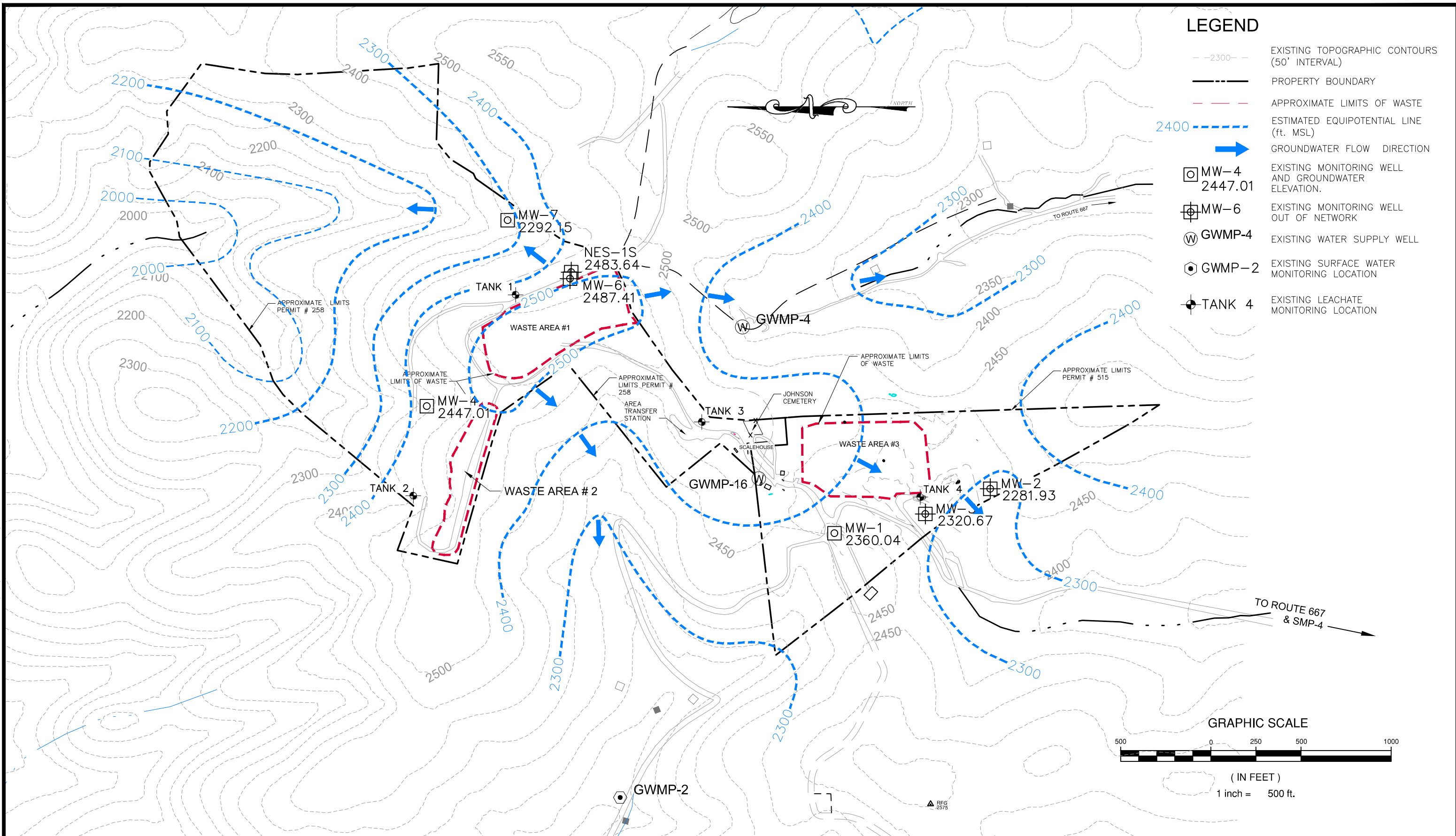

**Draper Aden Associates**  
*Engineering • Surveying • Environmental Services*  
 2206 South Main Street Blacksburg, VA 24060 540-552-0444 Fax: 540-552-0291  
 Richmond, VA Charlottesville, VA Hampton Roads, VA Raleigh, NC Fayetteville, NC Northern Virginia

DESIGNED WMD  
 DRAWN DLD  
 CHECKED SN  
 DATE 9/20/18

POTENTIOMETRIC SURFACE MAP - APRIL 30, 2018  
**RUSSELL COUNTY LANDFILL**  
 RUSSELL COUNTY, VIRGINIA

SCALE: 1"=500'  
 PLAN NO. B13159B-01

FIGURE  
**2**



# **Russell County BOS**

## **VDOT Update**

### **September 2, 2021**

#### **Route 615 Slide (Back Valley)**

VDOT is nearing completion of a plan of action for this slide. The anticipated repairs are anticipated to focus on stabilizing the road platform. Efforts are continuing to identify funding for the repairs.

#### **Pure Salmon Project**

VDOT has received the internal road plans for the project. The proposed connection to Route 19 was previously approved. We understand Industrial Access funds may be pursued for the construction of the road. The residency will review the plans with Industrial Access fund requirements in mind.

#### **St Paul Welcome Center**

The residency understands plans are moving forward for the welcome center in St Paul along Alternate Route 58. Residency staff look forward to reviewing plans for the project.

#### **Maintenance Activities**

Maintenance crews are actively involved in a variety of activities. Some hand patching continues as work load and weather conditions allow. Patching activities are anticipated to continue through the summer interspersed with other maintenance activities.

Slurry sealing and repaving of various routes within the County basically complete.

Mowing continues on 2-lane primary secondary routes.

Stabilized (gravel) roads are being worked along with ditching at various locations in the County.

The drain pipe replacement on Rt 67 just west of the intersection with Pine Creek has been rescheduled and is anticipated to be completed in August.

The section of Route 601 impacted by slide repairs last fall has been repaved.

#### **Tumbez Hollow Rural Rustic Drainage Resolution**

Residency staff is continuing work on an agreement with a private landowner for other work included in the project as well as continuing environmental permitting efforts.

#### **Thomas Warner Rural Rustic Project**

The residency has not yet received environmental clearance yet, but intends to begin construction shortly after receiving clearance.

## **Construction Projects**

The bridge replacement on Route 663 (Rocky Fork Road) for which the Board approved closure of the route in June will be closed on or near September 1<sup>st</sup>. This is a slight delay from the original anticipated closure date but the completion date of early December is not anticipated to be impacted.

Residency staff stand ready to respond to inquiries and provide explanations but also offer the 1-800-FOR-ROAD call to enter work order requests into VDOT's tracking system.



Staci A. Henshaw, CPA  
Auditor of Public Accounts

# Commonwealth of Virginia

*Auditor of Public Accounts*

P.O. Box 1295  
Richmond, Virginia 23218

August 5, 2021

The Honorable Ann S. McReynolds  
Clerk of the Circuit Court  
County of Russell

Rebecca Dye, Board Chairperson  
County of Russell

Audit Period: April 1, 2020, through March 31, 2021  
Court System: County of Russell

We have audited the cash receipts and disbursements of the Clerk of the Circuit Court for this locality for the period noted above. Our primary objectives were to test the accuracy of financial transactions recorded on the Court's financial management system; evaluate the Court's internal controls; and test its compliance with significant state laws, regulations, and policies.

## Management's Responsibility

Court management has responsibility for establishing and maintaining internal controls and complying with applicable laws and regulations. Internal control is a process designed to provide reasonable, but not absolute, assurance regarding the reliability of financial reporting, effectiveness and efficiency of operations, and compliance with applicable laws and regulations. Deficiencies in internal controls could possibly lead to the loss of revenues or assets, or otherwise compromise fiscal accountability.

We noted no matters involving internal control and its operation necessary to bring to management's attention.

Ann S McReynolds, Clerk of the Circuit Court  
Rebecca Dye, Board Chairperson  
August 5, 2021  
Page Two

We acknowledge the cooperation extended to us by the Clerk and her staff during this engagement.

Staci Henshaw  
AUDITOR OF PUBLIC ACCOUNTS

SAH:rh

cc: The Honorable Brian K. Patton, Chief Judge  
Lonzo Lester, County Administrator  
Paul F. DeLosh, Director of Judicial Services  
Supreme Court of Virginia  
Director, Admin and Public Records  
Department of Accounts

Power Poles: Appalachian Power Co.  
Telephone Poles: Chesapeake & Potomac Telephone Co.

DESIGN FEATURES RELATING TO CONSTRUCTION OR TO REGULATION AND CONTROL OF TRAFFIC MAY BE SUBJECT TO CHANGE AS DEEMED NECESSARY BY THE DEPARTMENT.

PUB. ROAD REGION	STATE	FEDERAL AID		STATE		SHEET NO.	TOTAL SHEETS
		ROUTE	PROJECT	ROUTE	PROJECT		
2	VA.			637	0037-083-003 Budget Item 3009	3	4

Rev 3-24-70

# Hwy System Changes APPROVED 04-07-1975

18-88	J.C.B.	DESIGNED
18-89	J.C.B.	ALIGNED
18-90	J.C.B.	CHECKED
18-91	J.C.B.	RT. OF WAY CHECKED
18-92	J.C.B.	NO.

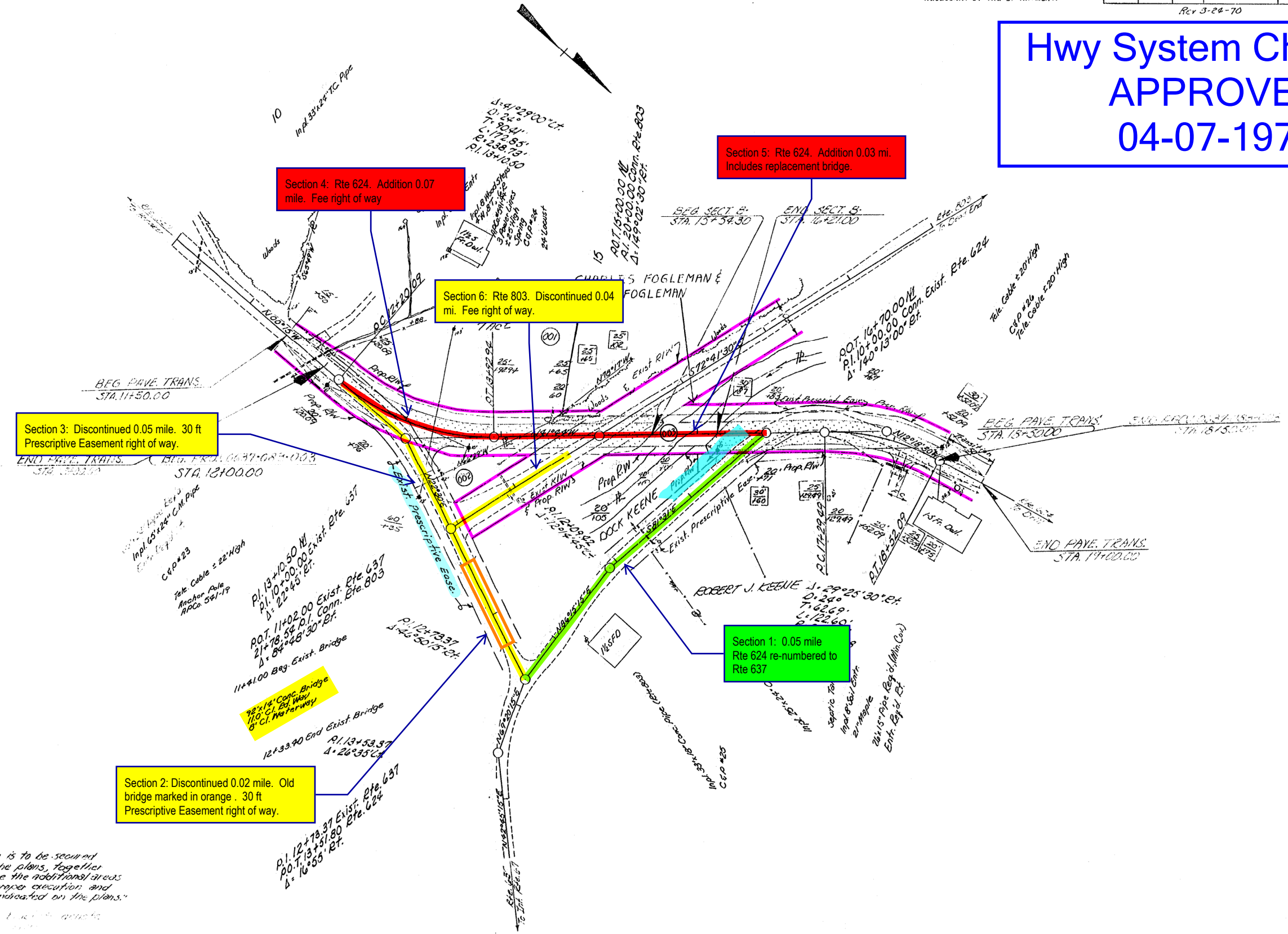

Note: A minimum 40-foot right of way is to be secured based on the centerline shown on the plans, together with the right and easement to use the additional areas shown as being required for the proper execution and maintenance of the work as indicated on the plans.

Note: Discontinued sections are to be marked as shown on the plans.

Note: Bearings based on Magnetic North

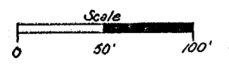



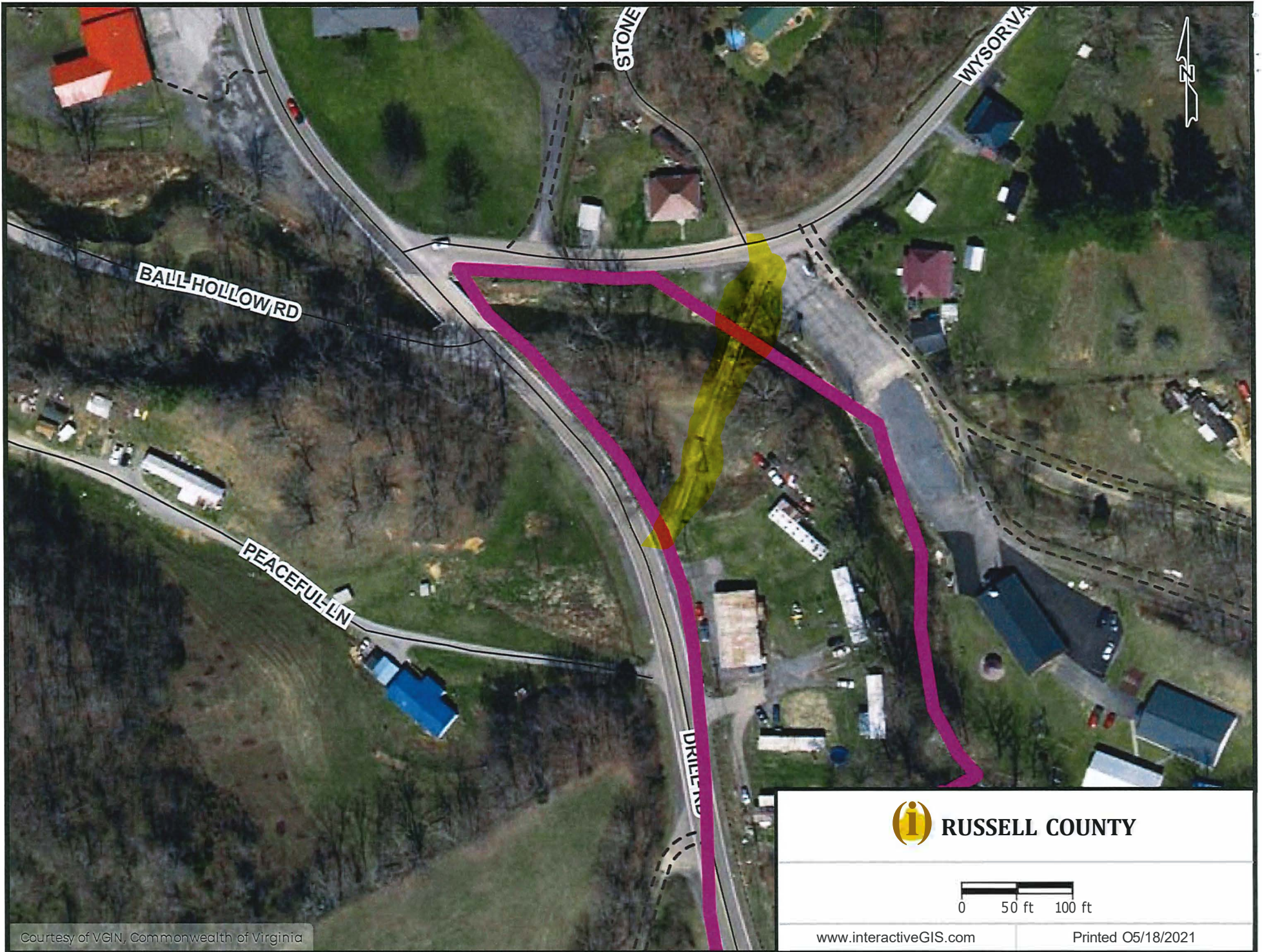

Courtesy of VGN, Commonwealth of Virginia

 **RUSSELL COUNTY**

0 50 ft 100 ft

[www.interactiveGIS.com](http://www.interactiveGIS.com)

Printed 05/18/2021



Print Date: 10/30/2020

# RUSSELL COUNTY VA

Map#: 76R 2067      Owner: **MARTIN MICHAEL LEE**  
 Record: 13248-1      66 KENTS RIDGE RD  
 911 Adr: 0 404 DRILL RD      HONAKER VA      24260  
 Sale Price: 0      Ratio: 0.00

Occupancy:      Zoning:      Use Class:

Exterior	Interior	Site
Construction: WOOD FRAME	No. Rooms: 0	Street: PAVED
Exterior Walls: CNDR BLOCK	No. Bedrooms: 0	Street:
Foundation: CONCRETE	No. Baths: 0F / 0H	Utilities: SEPTIC
Roofing: ASPHALT	Floors: TILE	Utilities: WELL
SHED	Floors: TILE	Acreage: 0.000
	Interior: SHEET ROCK	Year Built: 1965
		Stories: 1.00
		Air Condition: Y

Mthd	Cls	Land Description	Grd	Unit Size	Dept	Rate	Adj	Value
A	1		A	0	0.00	0.00	10000.0	10000

## Dwelling Valuation

Item	Qty	Size	Rate	Value
------	-----	------	------	-------

*\* 1932 Brick Apt*  
*\* Rt 803 Ball Hollow Road*  
*Rt 637 Wagon Valley Road*  
*\* 1975*  
*\* Discontinued (Prescriptive R/W) Easement 30ft*  
*\* Administrative, Not Maintenance*  
*\* Public Hearing - Acknowledgment of R/W Easement*

Improvement	Length	Width	Condition	Deprc.	Total Value
M/H DECK					200
M/H DECK					300
M/H PORCH					100
M/H PORCH					300
M/H PORCH					600
M/H PORCH					200

Description	Story	Size	Class	Factor	Rate	Value
STORAGE		84			0.00	302
PORCH		0			0.00	1000
RETAIL STORE		2048			0.00	16589

```

+--14-----+
 6STG      6
+-11-----+14-----+-----53-----+
:
:
:
:
:
:
:
32
:
:
:
:
:A
+-----64-----+
  
```

Instrument #	Assessed Value:	64,600
Deed Book	Replacement Value:	0
0510 - 695	Grade Factor ( D)	0.75
User Codes:	Phys Depr. % ( 0.000)	0
	Dwelling Value:	0
	Commercial	32900
<u>Date Inspected</u>	Previous Values	
20180423	Bldg 40000	<b>Total Imp. 54,600</b>
<u>At Home</u>	Land 10000	<b>Total Land 10,000</b>
<u>Initials</u>	Total	<b>Total Prop. 64,600</b>
CW		<b>Land Use Value</b>

Remarks: \_\_\_\_\_

SANITATION OFFICER

Upon motion made, seconded and duly passed by the Board that Kenneth Frank Ball of Honaker, Va. be hired as Sanitation Officer under Public Service Employment Program, Title II.

Meeting adjourned,

A Cerkoflloard ;7/2: /AJJYL!

R. W. Dickenson  
Chairman

March 3, 1975

At a regular meeting of the Russell County Board of Supervisors held at the Courthouse in Lebanon, Virginia on Monday, March 3, 1975 at 10:00 a.m.

- PRESENT: R. W. Dickenson, Chairman
- Miles Hillman
- R. H. Puckett
- Dr. Roy Smith
- Robert J. Bobic, Clerk of Board
- H. D. Campbell, D. S.

Meeting called to order.

Minutes of meetings of February 3 and 7th were read and approved.

RURAL TRANSPORTATION PLAN

Harold Lindsey appeared before the Board in regard to proposed transportation plan for Cumberland Plateau four county area, Board advised they would study these plans and take under advisement.

AREAWIDE AGENCY FOR AGING  
APPALACHIAN AGENCY FOR SENIOR CITIZENS, Inc.

Upon motion made by ;Herman Puckett, seconded by Roy R. Smith and duly passed by Board that following resolution be adopted:

RES O L U T I O ' N

WHEREAS, by earlier resolution, it was resolved to establish an areawide agency on aging lmot-m as the Appalachi n Agency for Senior Citizens, Inc., and

WHEREAS, it is necessary for the counties party to this agreement to establish the powers, duties, prbrileges and authority of said agency,

NOW, THEREFORE, BE IT RESOLVED:

(a) That the undersigned counties do hereby establish Articles of Incorporation for a non-stock, not-for-profit corporation kno m as the Appalachian Agency for Senior Citizens, Inc., said Articles being attached hereto and made a part hereof:

(b) That the duration of the corporation is to be perpetual, unless terminated by the members as set forth hereinafter;

(c) That the corporation shall exercise all powers belonging to, and inherent in, a corporation in the Commonwealth of Virginia, and shall also exercise such powers belonging to or inherent in the undersigned Boards of Sup l:visors, which may be lawfully delega-t:ed by same by virtue of Section 15.1-21, Virginia Gode, in order to carry out the purposes of the corporation:

(d)'That the purposes of the corporation shall be to exist and function as the official "area agency" for Buchanan, Dickenson, Russell and/or Tazewell Counties and to do all those things permitte and/or required by the Older Americans Act, 42 U.S. Code, Chapter 35, of an "area agency'", including planning, execution of services and coordination of services for the four county area;

J

J

J

j

J

-----, --px ohibited by the "Older Americans Act". This will include any and all grants of the "federal" and "state" government, and such funds as members shall donate from time to time or as shall be required of the agency or members for local participation in any "federal" and/or "state" grant.

(f) That the corporation shall be terminated by majority vote of the members upon termination of area agencies under the Older Americans Act or the repeal of that Act. Any property belonging to the corporation at the time of termination shall be divided as equally as possible among all members, and if not equally divisible, then sold, exchanged or assigned to the highest public bidder after sufficient public notice for four weeks, the proceeds to be divided equally among all members. Any provisions herein contrary to Federal or State law shall not be applicable.

(g) That this resolution of agreement shall be effective for each county when executed by the Board of Supervisors for that particular county, pursuant to majority vote.

he Vote was:

Aye: All members

Nay: None

ARTICLES OF INCORPORATION  
OF  
THE APPALACHIAN AGENCY FOR SENIOR CITIZENS, INC.

This is to certify that we, the undersigned, desire to, and hereby do, associate to incorporate exclusively on a not-for-profit basis under the provisions and subject to the requirements of law of the Commonwealth of Virginia.

ARTICLE I

The name of the corporation shall be the Appalachian Agency for Senior Citizens, Inc.

ARTICLE II

This non-stock, not-for-profit corporation is organized entirely for the purpose of being the official agency for the Counties of Buchanan, Russell and Tazewell, Virginia, to plan, implement and coordinate services pursuant to and as permitted by Chapter 35, Title 42 of the U.S. Code, commonly known as the Older Americans Act, an Act designed to promote, through planning and grants, a higher level of social services for older or senior citizens.

ARTICLE III

The corporation shall be non-stock.

ARTICLE IV

There shall be one class of three members, whose voting rights are restricted as set forth in Article VII hereinafter.

ARTICLE V

The Board of Directors shall consist of 12 individuals. The Boards of Supervisors of each county aforementioned shall choose four members each, initially one member from each county serving a period of three years, two members from each county serving for a period of two years, and one member from each county serving for a period of one year. Thereafter, each newly appointed member shall serve for a period of two years. A director must be a duly qualified elector and taxpayer of the county from which he is chosen. A director may be elected to succeed himself. Any vacancy on the Board of

...unexpired by ;ajo;ity ;t -- f- he Board of Superv sors w o appointed t e  
resigning, deceased or disabled director,

#### ARTICLE VI

The Corporation shall purchase and maintain an insurance policy on behalf of any person who is a director or officer of said corporation to protect against any liability or claim asserted against him arising out of his capacity as such, whether or not the corporation has the power to indemnify him against such liability under the provisions of Section 13.1-3.1 of the Code of Virginia.

#### ARTICLE VII

The corporation may be terminated by majority vote of the members upon the termination of "area agencies" under the Older Americans Act, the termination or repeal of that Act, or the failure of the State Agency on Aging to designate the Corporation as an official area agency. Any property belonging to the Corporation at the time of termination shall be divided as equally as possible among all members, and if not divisible, then sold, exchanged or assigned to the highest public bidder after sufficient public notice for four weeks, and the proceeds divided equally among all members, Any provision herein contrary to Federal or State law shall not be applicable.

#### ARTICLE VIII

The initial registered office shall be located at the offices of White, Elliott & Bundy Attorneys, Post Office box 600, Flannagan Avenue, Lebanon, Virginia 24266. The initial registered agent shall be James Wm.Elliott, Jr., whose business address is the same as the initial registered office, and who is a resident of Virginia and a member of the Virginia State Bar,

#### ARTICLE IX

The number of directors constituting t e initial Board of Directors shall be 12. They are:

Lawrence Lindsay - Vansant Virginia 24656  
Marie Owens - Vansant, Virginia 24656  
H. M. Thomas - Grundy, Va. 24614  
Grace Woolridge - Oakwood, Virginia 24631  
Ru.th Adkins - Cedar Bluff, Virginia 24609  
Paul Brown - Honaker, Virginia 24260  
Dewey Cain - Dante, Virginia 24237  
Charles McFarlane - Lebanon, Virginia 24266

#### ARTICLE X

The corporation shall be of perpetual duration, unless terminated as set forth by a majority vote of the embers hereof.

#### ARTICLE XI

The number of directors may only be changed by amendment to the  
Articles of Incorporation,

SCHOOL BOARD

Upon motion made by Herman Puckett, seconded by Miles Hillman and duly passed the following resolution was adopted:

R E S O L U T I O N

WHEREAS, the 1974-75 School Operation Budget reflects a 40% increase over the 1973-74 school budget for purpose of purchasing fuel for Russell County Schools; and

WHEREAS, the fuel cost through March 3, has exceeded the total 1974-75 budget appropriations by \$22,662.74; and

WHEREAS, it is anticipated that additional fuel will be purchased before the end of the 1974-75 fiscal year.

NOW, THEREFORE, BE IT RESOLVED, that the Russell County School Board requests permission of the Board of Supervisors to make transfer of appropriations in the amount of \$9,000.00 from Summer School 17h and \$21,000.00 from School Food Services 17e to Operation of School Plant 17fi,

BE IT FURTHER RESOLVED, that the County School Operations Budget appropriation be changed as follows:

17a Administration	\$ 116,592.00
17b1 Instruction	3,737,020.00
17b3 Other Instructional costs	539,182.00
17c Attendance & Health Services	99,660.00
17d1 Pupil Transportation Services	381,698.00
17d2 Replacement Transp. Vehicles	59,844.00
17e School Food Services	529,000.00
17f1 Operation of School Plant	384,151.00
17f2 Maintenance of School Plant	162,495.00
17g Fixed Charges	128,955.00
17h Summer School	16,850.00
17i Adult Education	63,171.00
17j Other Educational Programs	15,000.00
	<u>96,233,618.00</u>

The Vote was:

Aye: All members.  
Nay: None

RUSSELL COUNTY SCHOOL BOARD

Upon Motion made, seconded and duly passed by Board that following resolution be adopted:

R E S O L U T I O N .

WHEREAS, under the County Board form of Government, the Russell County Board of Supervisors has the absolute power to appoint the County School Board members; and

WHEREAS, under both State law and the Russell County School Board regulations, it was always understood that after the "AT LARGE" Supervisor had been elected that additional members of the School Board would be appointed; and

WHEREAS, acting under the authority of Section 22-61 of the 19-50 Code of Virginia, as amended, the Russell County Board of Supervisors did appoint Clyde Bostic and Clyde Grizzle to the Russell County School Board on June 21, 1974; and

WHEREAS, two of the members of the Russell County School Board have deliberately flaunted the decision of the duly elected representatives of Russell County by refusing to allow the said Bostic and Grizzle to take their seats and to have their votes counted on the Russell County School Board and have thereby caused millions of dollars of Russell County tax funds to be spent without proper legal sanction; and

## SCHOOL BOARD

Upon motion made by Herman Puckett, seconded by Miles Hillman and duly passed the following resolution was adopted:

## R E S O L U T I O N

WHEREAS, the 1974-75 School Operation Budget reflects a 40% increase over the 1973-74 school budget for purpose of purchasing fuel for Russell County Schools; and

WHEREAS, the fuel cost through March 3, has exceeded the total 1974-75 budget appropriations by \$22,662.74; and

WHEREAS, it is anticipated that additional fuel will be purchased before the end of the 1974-75 fiscal year.

NOW, THEREFORE, BE IT RESOLVED, that the Russell County School Board requests permission of the Board of Supervisors to make transfer of appropriations in the amount of \$9,000.00 from Summer School 17h and \$21,000.00 from School Food Services 17e to Operation of School Plant 17fi.

BE IT FURTHER RESOLVED, that the County School Operations Budget appropriation be changed as follows:

17a Administration	\$116,592.00
17b1 Instruction	3,737,020.00
17b3 Other Instructional costs	539,182.00
17c Attendance & Health Services	99,660.00
17d1 Pupil Transportation Services	381,698.00
17d2 Replacement Transp. Vehicles	59,844.00
17e School Food Services	529,000.00
17f1 Operation of School Plant	384,151.00
17f2 Maintenance of School Plant	162,495.00
17g Fixed Charges	128,955.00
17h Summer School	16,850.00
17i Adult Education	63,171.00
17j Other Educational Programs	15,000.00
	<u>\$6,233,618.00</u>

The Vote was:

Aye: All members  
Nay: None

## RUSSELL COUNTY SCHOOL BOARD

Upon Motion made, seconded and duly passed by Board that following resolution be adopted:

## R E S O L U T I O N .

WHEREAS, under the County Board form of Government, the Russell County Board of Supervisors has the absolute power to appoint the County School Board members; and

WHEREAS, under both State law and the Russell County School Board regulations, it was always understood that after the "AT LARGE" Supervisor had been elected that additional members of the School Board would be appointed; and

WHEREAS, acting under the authority of Section 22-61 of the 1950 Code of Virginia, as amended, the Russell County Board of Supervisors did appoint Clyde Bostic and Clyde Grizzle to the Russell County School Board on June 21, 1974; and

WHEREAS, two of the members of the Russell County School Board have deliberately flaunted the decision of the duly elected representatives of Russell County by refusing to allow the said Bostic and Grizzle to take their seats and to have their votes counted on the Russell County School Board and have thereby caused millions of dollars of Russell County tax funds to be spent without proper legal sanction; and



have accomplished the above by holding illegal meetings and electing illegal chairman in violation of Virginia law and Russell County School regulations; and

WHEREAS, this Board has, after an exhaustive study, concluded that there is much mismanagement and waste and politics in the Russell County School System;

NOW, THEREFORE, BE IT RESOLVED by the Russell County Board of Supervisors that henceforth no tax funds of this County over \$25,00 shall be expended by or for the Russell County School System or any program under its jurisdiction unless it be paid by check countersigned by the Russell County Administrator; and

BE IT FURTHER RESOLVED, that the Russell County Administrator is hereby ordered not to countersign any such check without first receiving the contract, order, or invoice upon which the expenditure is based signed by no less than three of the five members of the Russell County School Board as approving the same; and

BE IT FURTHER RESOLVED, that subject to the laws of Virginia, anyone signing any such check over \$25.00 from Russell County funds for any School Board expense without a copy of such signed contract or invoice shall be held personally liable for the same and the Commonwealth's Attorney (with the help of the law firm of Smith, Robinson and Vinyard if necessary) is hereby instructed to take any and all legal proceedings to regain any sums spent or paid in violation of this resolution.

The only EXCEPTION to this resolution shall be checks to teachers bus drivers, maintenance personnel, cafeteria workers, and other school personnel hired for the 1974-75 school year paid for salary under their contracts. Such salary checks may be paid without the contracts but they must nevertheless be signed by the County Administrator.

The Vote was:

Aye: Dr. Roy Smith, Miles Hillman and R. W. Dickenson

Herman Puckett abstained from voting,

#### TOWN HALL BUILDING

Richard Cozzolino, Town Manager appeared before the Board with regard to negotiating sale of old town hall building to the County. The purchase price asked was \$22,500,00 plus seven year free lease for ground floor section to be used by Fire Department as now being occupied.

Board advised they would consider said offer and advise of their decision by Thursday of this week.

#### RUSSELL COUNTY WATER & SEWER AUTHORITY

Upon motion made, seconded and duly passed by the Board that the following named be and hereby is appointed to the Russell County Water and Sewer Authority Committee for a three year term to run from 3-6-75 thru 3-6-78:

1. John Minahan
2. Fred Phillips
3. E. D. Hilton
4. H. B. Compton
5. Stan Banner (replacing Jack Milton).

COSTS RELATING TO CANNERIES TO  
BE PAID FROM REVENUE SHARING

Upon motion made, seconded and duly passed by Board that W. W. Barrett, Treasurer, be and hereby is directed to pay to Beeson & Beeson, Architects, Charles R. Day, Associate, the amount of \$6,371.40 as architect's fee and to pay to J. G. Adams Builders, Inc., \$8,802.18 which said amount being due in accordance with Certificate for payment no. 1 with regard to work completed by J. G. Adams, Builders, Inc. on Castlewood and Honaker Canneries, less retainage of 10%. Said payments to be charged to Revenue Sharing account,

The Vote was:

Aye: All members .

Nay: None

LEBANON INSURANCE AGENCY

Upon motion made, seconded and duly passed that warrants be issued in payment of premiums due for policy no. SMP 398176 with USF & G \$1492, 00, this being second installment and policy no. 5XL 16 311 LMC Boiler & Machinery policy - three year term \$259.00; and policy OPJ 38934 USF & G Workmen's Compensation \$1847.00.

It is further resolved that coverage on Dante Community Center be added to coverage if not already insured,

The Vote was:

Aye: All members

Nay: None

DANTE COMMUNITY CENTER

Mr. Gene Hilton appeared before the Board with regard to materials needed to get Dante Community Center into operating condition and to get ramp constructed at building, the Board, upon motion made by Herman Puckett, seconded by Dr. Roy Smith and duly passed Robert J. Bobic, County Administrator, be authorized to work with Mr. Hilton in purchasing needed equipment for Center, and also authorize Jerry Ingle to construct ramp at labor bid of \$710.00.

BILLS APPROVED

Upon motion made, seconded and duly passed that bills, as presented, be and hereby are approved for payment,

SWORDS CREEK COMMUNITY CENTER

Upon motion made, seconded and duly passed that Robert J. Bobic, County Administrator be and he hereby is authorized to work with personnel of Swords Creek Community Center with regard to purchasing needed furnishings and materials to repair said building.

RUSSELL COUNTY EDUCATION ASSOCIATION

Cheryl Wallace, representing Russell County Education Association appeared before Board and presented signed petitions from teachers of each County school asking that when considering 75-76 budget that county pay 100% of health insurance coverage; 12% cost of living expenses and relief from duty thru teacher aids of at least one period each day. Mrs. Wallace state. that health insurance coverage was first priority and that several Insurance Companies had been asked to present bids for said group coverage.

1

HIGHWAY DEPARTMENT

Upon motion made, seconded and duly passed that following resolution be adopted:

R E S O L U T I O N

WHEREAS, Secondary Route 637, from Int. Rte. 624 to 0.07 MS Rte. 803, a distance of 0.10 miles, has been altered, and a new road has been constructed and approved by the State Highway Commissioner, which new road serves the same citizens as the road so altered; and

WHEREAS, certain sections of this new road follow new locations, these being shown on the attached sketch titled, "Changes in Secondary System Due to Relocation and Construction on Route 637, Budget Item 0637-6054 dated at Lebanon, Virginia February 24, 1975.

NOW, THEREFORE, BE IT RESOLVED: That the portions of Secondary Route 637, i.e., Section 4 and 5, shown in red on the sketch titled, "Changes in Secondary System Due to Relocation and Construction on Route 637, Budget Item 0637-6054, dated at Lebanon, Virginia February 24, 1975", a total distance of 0.10 miles, be and hereby is, added to the Secondary System of State Highways, pursuant to Section 33.1-229 of the Code of Virginia of 1950, as amended;

AND FURTHER, that the State Highway Commission be requested to take necessary action to discontinue the sections of old location, i.e., Section 2 and 3, shown in yellow on the aforementioned sketch, a total distance of 0.07 miles, as a part of the secondary System of State Highways as provided in Section 33.1-150 of the Code of Virginia of 1950, as amended,

HIGHWAY DEPARTMENT

Upon motion made, seconded and duly passed by Board that following resolution be adopted:

R E S O L U T I O N

WHEREAS, Secondary Route 803, from Original Rte. 637, to new location Rte. 637, a distance of 0.04 miles has been altered, and a new road has been constructed and approved by the State Highway Commissioner, which new road serves the same citizens as the road so altered; and

WHEREAS, certain sections of this new road follow new locations, these being shown on the attached sketch titled, "Changes in Secondary System Due to Relocation and Construction on Route 803, Budget Item 0637-6054 dated at Lebanon, Virginia February 24, 1975."

And further, that the State Highway Commission be requested to take the necessary action to discontinue the sections of old location, i.e., Sections 6, shown in yellow on the aforementioned sketch, a total distance of 0.04 miles, as a part of the Secondary System of State Highways as provided in Section 33.1-150 of the Code of Virginia of 1950, as amended.

HIGHWAY DEPARTMENT

Upon motion made, seconded and duly passed by the Board that the following resolution be adopted:

R E S O L U T I O N

WHEREAS, Secondary Route 636, from Int. Rte. 633, to 0.22 miles S.E. Rt. 633, a distance of 0.22 miles, has been altered and a new road has been

u

U

WHEREAS, certain sections of this new road follow new locations, these being shown on the attached sketch titled, "Changes in Secondary System Due to Relocation and Construction on Route 636, Project 0636-083-133, G5Q1 dated at Richmond, Virginia 2-20-75."

NOW, THEREFORE, BE IT RESOLVED: That the portions of Secondary Route 636 i.e, section 2, shown in red on the sketch titled, "Changes in Secondary System Due to Relocation and Construction on Route 636, Project 0636-083-133, G501, dated at Richmond, Virginia 2-20-75", a total distance of 0.443 miles, be and hereby is, added to the Secondary System of State Highways, pursuant to Section 33.1-229 of the Code of Virginia of 1950, as amended.

And further, that the section of old location, i.e., Section 3, shown in blue on the aforementioned sketch, a total distance of 0.14 miles, be, and the same hereby is abandoned as a public road, pursuant to Section 33.1-155 of the Code of Virginia of 1950, as amended,

1975 National Wildlife Week Proclamation

Upon motion made, seconded and duly passed that the following resolution be adopted, .:

R E S O L U T I O N

WHEREAS, the Wildlife bestowed by Nature upon our world has ever been a source of beauty, inspiration and enjoyment to the people of Russell County; and,

WHEREAS, this same wildlife brings many other benefits to man and his civilization; and

WHEREAS, many forms of wildlife are prospering, many others need our help; and

WHEREAS, citizen concern is always needed, to foster and perpetuate conditions enhancing survival of wildlife; and

WHEREAS, the preservation of wildlife habitat is the single most important factor in wildlife conservation; and.

WHEREAS, the period March 16 - 22, 1975 has been designated as a special time for expression of concern for wildlife habitat; now, therefore,

BE IT RESOLVED, that the Board of Supervisors of Russell County do hereby join the National Wildlife Federation in proclaiming March 16 - 22, 1975, as National Wildlife Week, urging our citizenry to affirm with the Federation that "We Care About Wildlife Habitat."

Meeting adjourned.

Clerk: Irta

*R. W. Dickenson*  
Chairman

MARCH 6, 1975

At a called meeting of the Russell County Board of Supervisors held at Courthouse in Lebanon, Va. on March 6, 1975.

PRESENT: R. W. Dickenson, Chairman  
Miles Hillman  
R. H. Puckett  
DR. Roy Smith  
Robert J. Bobic, Clerk of Board  
Frank Norris, Resident Engineer - Dept. of Highways

Meeting called to order.

## RUSSELL COUNTY SCHOOL BOARD

Upon motion made by Miles Hillman, seconded by Roy Smith and duly passed by Board that following resolution be adopted:

## RESOLUTION

WHEREAS, \$614,400 was appropriated in the 1974-75 Capital Outlay Budget for the construction of the Russell County Vocational School addition; and

WHEREAS, payments in the amount of \$578,742.44 have been made as of February 3, 1975; and

WHEREAS, Click Construction Company representative has estimated that as of June 30, 1975, they will have completed and billed the Russell County School Board for an additional \$575,000. in excess of the \$614,400. originally budgeted; and

WHEREAS, appropriations from the Board of Supervisors are insufficient to make full payment for the additional \$575,000. and construction cannot continue without said appropriation; and

WHEREAS, \$75,000 of the required \$149,500 local matching money is available, and can be transferred from the County School Operating Budget.

NOW, THEREFORE BE IT RESOLVED, that because of the aforementioned reasons, the Russell County School Board respectfully requests that the Russell County Board of Supervisors increase the Capital Outlay Budget appropriations by \$288,461 thus increasing the Capital Outlay Budget total from \$1,225,307 to \$1,513,768,

BE IT FURTHER RESOLVED, that the School Board requests that \$75,000. be transferred from the County School Operating Fund to the Capital Outlay and Debt Service Fund in order that construction may continue on the Russell County Vocational School addition,

The Vote was:

Aye: R. W. Dickenson, Miles Hillman and Roy Smith

R. H. Yuckett not present

## ANNUAL ROAD MEETING

The annual road meeting of representative of the Department of Highways with the Board of Supervisors and the citizens same having been advertised as required by statute, Mr. J. J. Norde, Resident Engineer for the Department of Highways for Russell County, met with the Board and discussed with the Board and citizens present, the plans and proposals for the expenditure of the Secondary Road Funds allocated to Russell County for the fiscal year beginning July 1, 1975, after which discussion the members of the Board of Supervisors agreed to submit their recommendations in order of priority at a later date,

Meeting adjourned.

Robert J. Hillman  
Clerk of Board

R. W. Dickenson  
Chairman

MARCH 14, 1975

At an adjourned meeting of the Russell County Board of Supervisors on Friday the 14th day of March, 1975, held at the Courthouse in Lebanon, Virginia at 10:00 a.m.

PRESENT: R. W. Dickenson, Chairman  
Miles Hillman  
Dr. Roy R. Smith

Upon motion made, seconded and duly passed by the Board that the following resolution be adopted:

R E S O L U T I O N

WHEREAS, the Russell County Board of Supervisors has had a suit filed against it by Harold Mitchell and C. B. Yates alleging to be a majority of the Russell County School Board; and

WHEREAS, S. Strother Smith, III, of the law firm of Smith, Robinson & Vinyard, is an Attorney who is especially knowledgeable about Virginia School Law and especially with the situation in Russell County; and,

WHEREAS, the Commonwealth's Attorney of Russell County is heavily overburdened with the criminal docket of Russell County;

THEREFORE, BE IT RESOLVED, that the Commonwealth's Attorney is hereby directed to retain the assistance of the law firm of Smith, Robinson & Vinyard to draw all pleadings and to assist in the arguing of said litigation, at an hourly rate of \$45.00 per hour, plus their expenses, as invoiced on a monthly basis, which fees, the County Administrator is hereby directed to pay.

The Vote was:

Aye: R. W. Dickenson, Miles Hillman and Dr. Roy R. Smith

R. H. Puckett not present.

Meeting adjourned.

*Robert J. Bobic*  
Clerk of Board

*R. W. Dickenson*  
Chairman

APRIL 7, 1975

At a regular meeting of the Russell County Board of Supervisors held at the Courthouse in Lebanon on April 7, 1975, at 10:00 a.m.

PRESENT: R. W. Dickenson, Chairman  
R. H. Puckett  
Miles Hillman  
Dr. Roy R. Smith  
H. D. Campbell, D.S.  
R. J. Bobic, Clerk of Board

Meeting called to order.

Minutes of meetings of March 3, March 6, and March 14, were read and approved.

LEBANON TOWN HALL

Upon motion made, seconded and duly passed by the Board that Tom of Lebanon be made the following offer with regard to purchasing the building located at the back of the courthouse formerly used by town offices:

1. \$15,000.00 purchase price with five year fee lease reserved for use by Fire Department of lower section of building as now occupied by said Fire Department; or

Jr

DEPARTMENT OF HIGHWAYS

April 7, 1975

Secondary y.t.m  
Addition RS  
Russell County

Board of Supervisors of Russell County  
Catalewood, Virginia 24214

Glutlellen:

As requested in resolution by your Board on March 3, 1975, the following addition to the secondary system of Russell county is hereby approved, effective April 7, 1975,

ADDITION

LENGTH

Sections 4 and 5 of new location Rte. 637  
from Int. Rte. 24 to 0.07 M, S. Rt. 803.

0.10 Mi.

Also file 15 c - (1/1/1e,3)

11 (Pr-631)

Sincerely,

J. B. Harwood, Deputy Commissioner  
and Chief Engineer (for [unclear])

Copies:

- Mr. A. S. Mattox
- Mr. J. P. Mills, Jr.
- Mr. A. S. Brown
- Mr. J. F. Turner
- Mr. L. H. Dawson, Jr.
- Mr. Frank Norris - Lebanon

-0.04

MAP REVISED BY APR 14 1975

CHECKED BY [signature]

RECORDED [signature]



Plotted on photo 242 (mid-1-189)

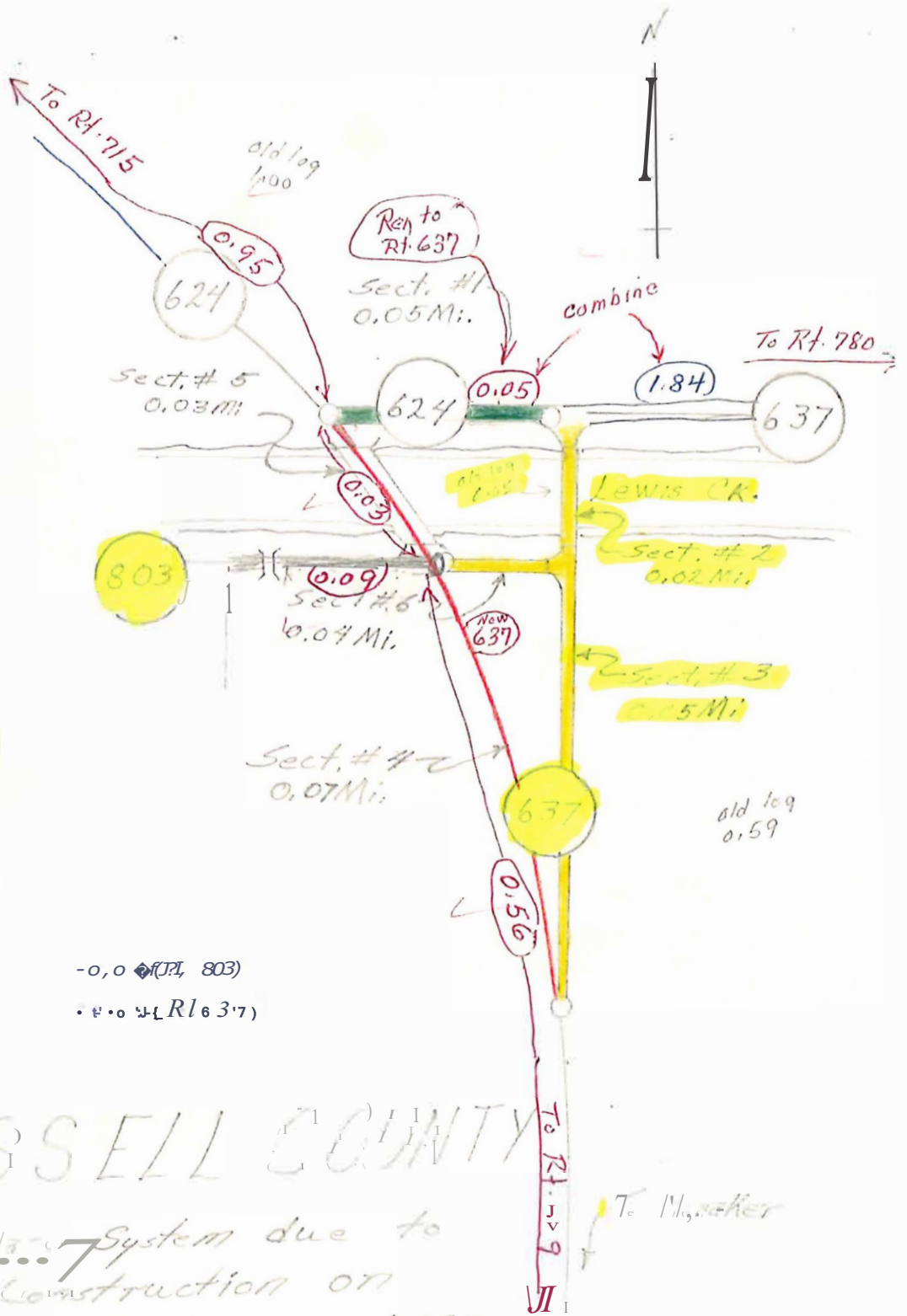

Primary, Secondary System due to Renovation and Construction on Route 637 at Int. Routes 624 & 803

- Section of old location to be abandoned - 0,00
  - Section of old location to be discontinued - Hawley, S. J. R. d. & It
  - Section of new location to be added to Secondary System
  - Section of original location to be renumbered Rte. 637
- Office of the State Highway Engineer, Raleigh, N.C. 2-24-75

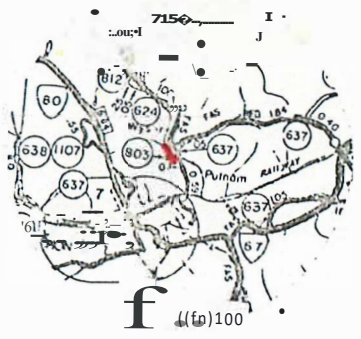
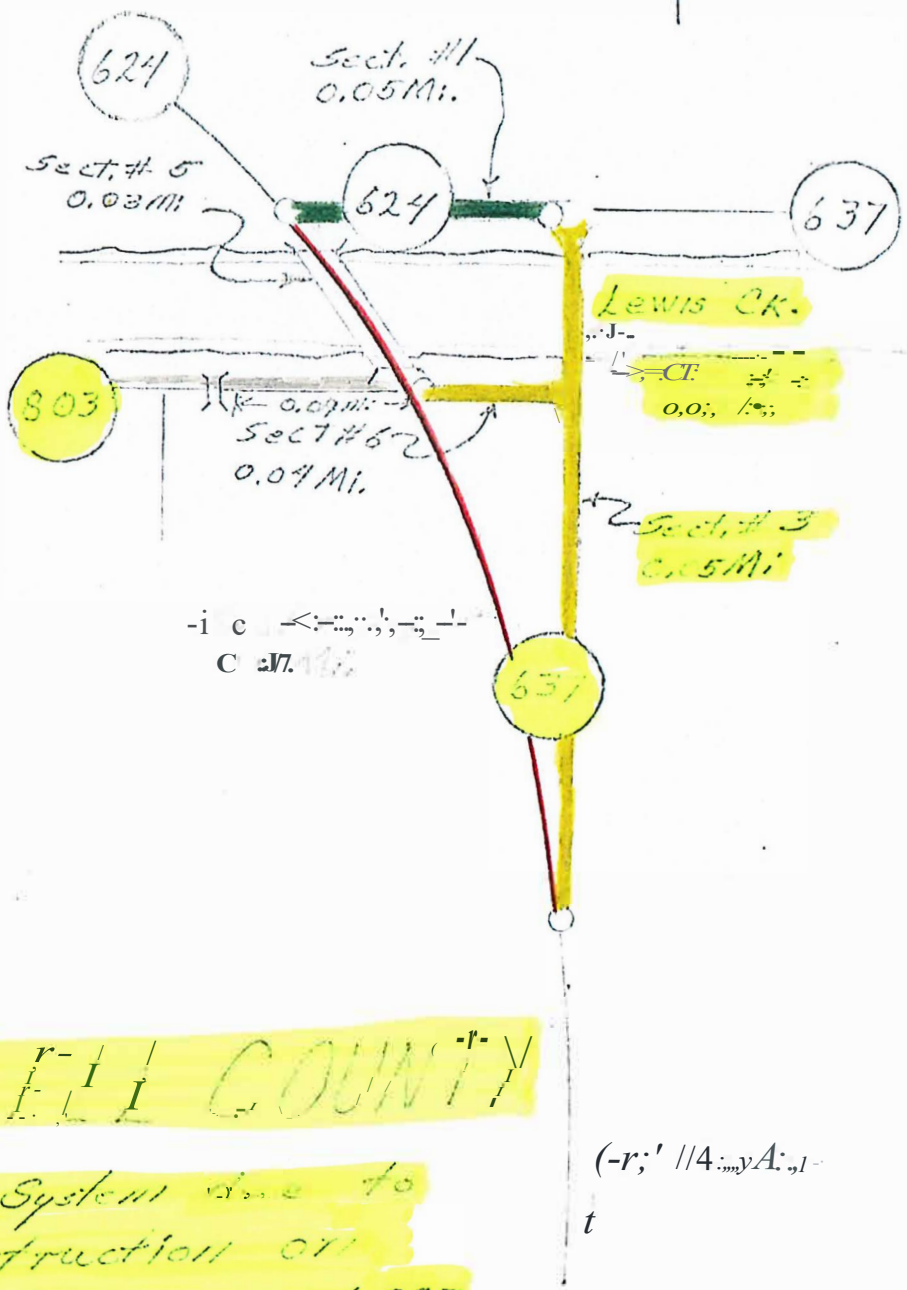

# RUSSELL COUNTY

Project 1, Secondary System due to abandonment and construction on Route 637 at Mt. Routes 624 & 803

- Section of old location to be abandoned
  - Section of old location to be discontinued
  - Section of new location to be added to Secondary System
  - Section of original Rte, 624 To be renumbered Rte. 637
- Office of The Resident Engineer Lebanon, VA. 7-7-50

**GOVERNOR'S AGRICULTURE & FORESTRY INDUSTRIES DEVELOPMENT  
FUND**

**PERFORMANCE AGREEMENT**

This **PERFORMANCE AGREEMENT** (the "Agreement") made and entered this \_\_\_\_ day of \_\_\_\_\_, 20\_\_, by and among the **COUNTY of RUSSELL, VIRGINIA** (the "Locality") a political subdivision of the Commonwealth of Virginia (the "Commonwealth"), and **RAMBLER STAVES, LLC dba RAMBLER WOOD PRODUCTS** (the "Company"), a limited liability company authorized to transact business in the Commonwealth, and the **INDUSTRIAL DEVELOPMENT AUTHORITY OF RUSSELL COUNTY** (the "Authority"), a political subdivision of the Commonwealth.

WITNESSETH:

WHEREAS, the Locality has been awarded a grant of and expects to receive \$300,000 from the Governor's Agriculture & Forestry Industries Development Fund (an "AFID Grant") through the Virginia Department of Agriculture and Consumer Services ("VDACS") for the purpose of inducing the Company to purchase and improve an agriculture and/or forestry processing/value-added facility using Virginia-grown products in the Locality (the "Facility"), thereby making a significant Capital Investment, as hereinafter defined, creating a significant number of New Jobs, as hereinafter defined; and purchasing a significant amount of Virginia-grown agricultural and forestal products, as hereinafter defined.

WHEREAS, the Locality is willing to provide the funds to the Authority with the expectation that the Authority will provide the funds to or for the use of the Company, provided that the Company promises to meet certain criteria relating to Capital Investment, New Jobs, and purchase of Virginia-grown agricultural and forestal products;

WHEREAS, the Locality, the Authority and the Company desire to set forth their understanding and agreement as to the payout of the AFID Grant, the use of the AFID Grant proceeds, the obligations of the Company regarding Capital Investment, New Job creation, purchase of Virginia-grown agricultural and forestal products, and the repayment by the Company of all or part of the AFID Grant under certain circumstances;

WHEREAS, the purchase and operation of the Facility will entail a capital expenditure of approximately \$7,565,000, of which approximately \$5,550,000 will be invested in machinery and equipment, approximately \$1,700,000 will be invested to improve the site and building, and approximately \$315,000 will be invested in tangible personal property;

WHEREAS, the purchase and operation of the Facility will further entail the creation of 73 New Jobs at the Facility;

WHEREAS, the purchase and operation of the Facility will further lead to the purchase of Virginia-grown agricultural and forestal products in the following amount: \$22,298,646 or 13,116,850 board feet over the performance period (see Appendix A for details); and

WHEREAS, the stimulation of the additional tax revenue and economic activity to be generated by the Capital Investment, New Jobs, and purchase of Virginia-grown agricultural and forestal products constitutes a valid public purpose for the expenditure of public funds and is the animating purpose for the AFID Grant:

NOW, THEREFORE, in consideration of the foregoing, the mutual benefits, promises and undertakings of the parties to this Agreement, and other good and valuable consideration, the receipt and sufficiency of which are hereby acknowledged, the parties covenant and agree as follows.

**Section 1. Definitions.**

For the purposes of this Agreement, the following terms shall have the following definitions:

“Capital Investment” means a capital expenditure by the Company in taxable real property, taxable tangible personal property, or both, at the Facility excluding the purchase of land or existing real property improvements. The total capital expenditure of \$7,565,000 is referred to in this Agreement as the “Capital Investment.” Only the capital expenditures allocated to the portion of the real property to be leased by the Company will count as “Capital Investment.” The purchase or lease of furniture, fixtures, machinery and equipment, including under an operating lease, and expected building up-fit and tenant improvements by or on behalf of the Company will qualify as Capital Investment.

“Grant Award Date” means January 15, 2021. This is the date from which progress towards the achievement of all Targets begins. Progress towards achievement of Targets before this date will not be counted, unless such progress is approved in writing by VDACS, in consultation with the Locality and Authority.

“Maintain” means that the New Jobs created pursuant to the AFID Grant will continue without interruption from the date of creation through the Performance Date. Positions for the New Jobs will be treated as Maintained during periods in which such positions are not filled due to temporary reductions in the Company’s employment levels in connection with recruitment for open positions or strikes and other work stoppages.

“New Job” means new permanent full-time employment of an indefinite duration at the Facility for which the standard fringe benefits are paid by the Company for the employee, and for which the Company pays an average annual wage of at least \$41,623. Each New Job must require a minimum of either (i) 35 hours of an employee’s time per week for the entire normal year of the Company’s operations, which “normal year” must consist of at least 48 weeks, or (ii) 1,680 hours per year. Seasonal or temporary positions, positions created when a job function is shifted from an existing location in the Commonwealth, and positions with construction contractors, vendors, suppliers and similar multiplier or spin-off jobs shall not qualify as New Jobs.

“Performance Date” means March 31, 2024. If the Locality, in consultation with the Authority and the Secretary of Agriculture and Forestry, deems that good faith and reasonable efforts have been made and are being made by the Company to achieve the Targets, the Locality may agree to extend the Performance Date by up to 15 months. If the Performance Date is extended, the Locality shall send written notice of the extension to the Authority, the Company and the Secretary of Agriculture

and Forestry and the date to which the Performance Date has been extended shall be the “Performance Date” for the purposes of this Agreement.

“Targets” means the Company’s obligations to make Capital Investments at the Facility of at least \$7,565,000, to create and Maintain at least 73 New Jobs at the Facility, and to purchase at least \$22,298,646 of Virginia-grown agricultural and forestal products as defined in Appendix A, all as of the Performance Date.

“Virginia Code” means the Code of Virginia of 1950, as amended.

## **Section 2. Targets.**

The Company will develop and operate the Facility in the Locality, make a Capital Investment of at least \$7,565,000, create and Maintain at least 73 New Jobs, and purchase \$22,298,646 or 13,116,850 board feet of Virginia-grown agricultural and forestal products (see Appendix A), at the Facility, all as of the Performance Date. If the dollar amount of new purchases of Virginia-grown agricultural and forestal products is not met, the Company can still achieve the purchase target by demonstrating they substantively achieved the same volume of Virginia-grown agricultural and forestal products they proposed in Appendix A.

The average annual wage of the New Jobs will be at least \$41,623.

The average prevailing wage in the locality in 2021 is \$40,421.

## **Section 3. Disbursement of AFID Grant.**

By execution and delivery of this Agreement, the Locality requests that the AFID Grant shall retain with VDACS until disbursed. The disbursement of the AFID Grant proceeds to the Company via the Locality and Authority will serve as an inducement to the Company to achieve the Targets. The AFID Grant process shall be retained by VDACS and shall be disbursed as follows:

(a) Achievement of Targets. The full \$300,000 AFID Grant Award shall be disbursed in full following submission of an annual report, as required in Section 5 of this Performance Agreement, that demonstrates to the satisfaction of the Locality, the Authority, and VDACS that it has made a Capital Investments of at least \$7,565,000, created and Maintained at least 73 New Jobs with an average annual wage of \$41,623, and purchased \$22,298,646 or 13,116,850 board feet of agricultural and forestal products (per Appendix A).

Within 30 days of the submission of sufficient documentation to confirm completion of Targets and submission of a valid request for payment of AFID Grant funds, VDACS shall disburse AFID Grant proceeds to the Locality. Within 30 days of receipt of AFID Grant proceeds, the Locality will disburse the AFID Grant proceeds to the Authority. Within 30 days of its receipt of such AFID Grant proceeds, the Authority will disburse such AFID Grant proceeds to the Company.

(b) Substantial Performance. If by the Performance Date, as verified by the Locality and VDACS, the Company has achieved at least ninety percent (90%) of the Targets, the company is eligible for the full \$300,000 AFID Grant Award.

Within 30 days of the submission of sufficient documentation to confirm Substantial Performance and submission of a valid request for payment of AFID Grant funds, VDACS shall disburse AFID Grant proceeds to the Locality. Within 30 days of receipt of AFID Grant proceeds, the Locality will disburse the AFID Grant proceeds to the Authority. Within 30 days of its receipt of such AFID Grant proceeds, the Authority will disburse such AFID Grant proceeds to the Company.

(c) Partial Performance. If by the Performance Date, the Company has failed to meet the Targets, the Company may still be eligible for a partial payment of the AFID Award. For purposes of determining partial payment, the AFID Grant is to be allocated as \$100,000 (33%) for the Company's Capital Investment Target, \$100,000 (33%) for its New Jobs Target, and \$100,000 (33%) for its purchase of Virginia-grown agricultural and forestal products. If the Company has not met at least ninety percent (90%) of each of the three of its Targets at the Performance Date, the Company shall no longer be eligible for that part of the AFID Grant that is proportional to the Target or Targets for which there is a shortfall. For example, if at the Performance Date, the Capital Investment is only \$5,673,750, only 55 New Jobs have been created and Maintained, and only \$16,723,985 or 9,837,638 board feet of Virginia-grown agricultural and forestal products have been purchased, the Company shall only be eligible for seventy-five percent (75%) of the moneys allocated to the Capital Investment Target (\$75,000), seventy-five percent (75%) of the moneys allocated to the New Jobs Target (\$75,000), and seventy-five percent (75%) of the moneys allocated to the purchase of Virginia-grown agricultural and forestal products Target (\$75,000).

Within 30 days of the submission of sufficient documentation to confirm Partial Performance and submission of a valid request for payment of AFID Grant funds, VDACS shall disburse the partial AFID Grant proceeds to the Locality. Within 30 days of receipt of AFID Grant proceeds, the Locality will disburse the AFID Grant proceeds to the Authority. Within 30 days of its receipt of such AFID Grant proceeds, the Authority will disburse such AFID Grant proceeds to the Company.

(d) *Determination of Inability to Comply:* If the Locality or the Secretary of Agriculture and Forestry (the "Secretary") determines at any time before the Performance Date (a "Determination Date") that the Company is unlikely to meet and Maintain at least fifty percent (50%) of its Targets by and through the Performance Date (i.e., by making a Capital Investment of at least \$3,782,500 in the Facility, to creating and Maintaining at least 37 New Jobs at the Facility, or purchasing at least \$11,149,323 or 655,843 board feet of Virginia-grown agricultural and forestal products by the Performance Date), and if the Locality or the Secretary shall have promptly notified the Company of such determination, eligibility for payment of AFID Grant Funds is forfeited and all AFID Grant Funds disbursed to the Company must be repaid by the Company to the Authority. Such a determination by the Locality or the Secretary will be based on such circumstances as a filing by or on behalf of the Company under Chapter 7 of the U.S. Bankruptcy Code, the liquidation of the Company, an abandonment of the Facility by



the Company or other similar significant event that demonstrates the Company will be unable or is unwilling to satisfy the Targets for the AFID Grant.

(e) *Use of the AFID Grant Proceeds:* The Company will use the AFID Grant proceeds to make building improvements, as permitted by Section 3.2-304(C) of the Virginia Code.

**Section 4. State and Local Government Incentives.**

See Appendix B for definition of “break-even point.” With regard to the Facility, the Commonwealth expects to provide incentives in the following amounts:

<u>Category of Incentive:</u>	<u>Total Amount</u>
AFID Grant	\$300,000
Virginia Jobs Investment Program (“VJIP”) (Estimated)	\$58,400

The Locality expects to provide the following incentives, as matching grants or otherwise, for the Facility:

<u>Category of Incentive:</u>	<u>Total Amount</u>
Russell County - Building lease-purchase agreement	\$1,500,000

The Locality has elected to enter into a building lease-purchase agreement with the Company in the amount of \$1,500,000 which lease period will end \_\_\_\_\_, 2031.

The proceeds of the AFID Grant shall be used for the purposes described in Section 3. The VJIP grant proceeds shall be used by the Company to pay or reimburse itself for recruitment and training costs. The proceeds of the Locality’s lease-purchase agreement may be used by the Company to take ownership of the building.

*Other Incentives:* This Agreement relates solely to the AFID Grant. The qualification for, and payment of all State-Level and Locality-Level Incentives, except for the AFID Grant, will be governed by separate arrangements between the Company and the entities offering the other incentives.

**Section 5. Company Reporting.**

The Company shall provide, at the Company’s expense, detailed verification reasonably satisfactory to the Locality, the Authority and VDACS of the Company’s progress on the Targets. Such progress reports will be provided annually, starting April 30, 2022, and at such other times as the Locality, the Authority or VDACS may reasonably require. The first progress report will cover the period from January 7, 2021, to March 31, 2022, the second progress report will cover the period from April 1, 2022, to March 31, 2023, and the third and final progress report will cover the period from April 1, 2023, to March 31, 2024.

With each such progress report, the Company shall report to VDACS the amount paid by the Company in the prior calendar year in Virginia corporate income tax. The Company hereby authorizes the Commissioner of the Revenue, the Treasurer and the Director of Finance for the Locality to release to the Authority and the Locality the Company’s confidential tax information and data so that

the Authority may verify the payments made. VDACS has represented to the Company that it considers such information to be confidential proprietary information that is exempt from public disclosure under the Virginia Freedom of Information Act and that such information will be used by VDACS solely in calculating aggregate return on invested capital analyses for purposes of gauging the overall effectiveness of economic development incentives.

With each progress report, the Company shall report to VDACS the number of New Jobs created and Maintained during the reporting period. The information provided will be verified by VDACS with the Virginia Employment Commission. If requested by VDACS, the Company shall provide to VDACS copies of the Company's quarterly filings with the Virginia Employment Commission covering the period from the date of this Agreement through the Performance Date. In accordance with the Virginia Code Section 60.2-114, VDACS is entitled to receive the Company's employment level and wage from the Virginia Employment Commission.

With each progress report, the Company shall also report to VDACS the amount purchased and the purchase price paid by the Company, or the fair market value of the Virginia-Grown Agricultural or Forestal Products utilized, through the prior year.

The Locality and Company agree to retain all books, records, data and other documents relative to this agreement for a period of three (3) years after the end of this agreement, or until audited by the Commonwealth of Virginia, whichever is sooner. VDACS and its authorized agents, and/or state auditors (both the Auditor of Public Accounts and/or VDACS Internal Auditor) shall have full access to and the right to examine any of said materials and records relating to this agreement during this period.

**Section 6.     Notices.**

Any notices required or permitted under this Agreement shall be given in writing, and shall be deemed to be received upon receipt or refusal after mailing of the same in the United States Mail by certified mail, postage fully pre-paid or by overnight courier (refusal shall mean return of certified mail or overnight courier package not accepted by the addressee):

if to the Company, to:

\_\_\_\_\_  
\_\_\_\_\_  
\_\_\_\_\_  
\_\_\_\_\_  
Attention: \_\_\_\_\_

with a copy to:

\_\_\_\_\_  
\_\_\_\_\_  
\_\_\_\_\_  
\_\_\_\_\_  
Attention: \_\_\_\_\_

if to the Locality, to:

\_\_\_\_\_  
\_\_\_\_\_  
\_\_\_\_\_  
\_\_\_\_\_  
Attention: \_\_\_\_\_

with a copy to:

\_\_\_\_\_  
\_\_\_\_\_  
\_\_\_\_\_  
\_\_\_\_\_  
Attention: \_\_\_\_\_

if to the Authority, to:

\_\_\_\_\_  
\_\_\_\_\_  
\_\_\_\_\_

Attention: \_\_\_\_\_

with a copy to:

\_\_\_\_\_  
\_\_\_\_\_  
\_\_\_\_\_

Attention: \_\_\_\_\_

if to VDACS, to:

Secretary of Agriculture and Forestry  
Office of Governor  
Commonwealth of Virginia  
1111 East Broad Street  
Richmond, Virginia 23219  
Attention: AFID

with a copy to:

Stephen Versen  
Manager, Office of Agriculture and Forestry  
Development  
Va Dept. of Agriculture & Consumer Services  
102 Governor St.  
Richmond, Virginia 23219  
Attention: AFID

**Section 7. Miscellaneous.**

(a) *Entire Agreement; Amendments:* This Agreement constitutes the entire agreement among the parties hereto as to the AFID Grant and may not be amended or modified, except in writing, signed by each of the parties hereto. This Agreement shall be binding upon and inure to the benefit of the parties hereto and their respective successors and assigns. The Company may not assign its rights and obligations under this Agreement without the prior written consent of the Locality, the Authority and the Secretary of Agriculture and Forestry.

(b) *Governing Law; Venue:* This Agreement is made, and is intended to be performed, in the Commonwealth and shall be construed and enforced by the laws of the Commonwealth. Jurisdiction and venue for any litigation arising out of or involving this Agreement shall lie in the Circuit Court of the Locality and such litigation shall be brought only in such court.

(c) *Counterparts:* This Agreement may be executed in one or more counterparts, each of which shall be an original, and all of which together shall be one and the same instrument.

(d) *Severability:* If any provision of this Agreement is determined to be unenforceable, invalid or illegal, then the enforceability, validity and legality of the remaining provisions will not in any way be affected or impaired, and such provision will be deemed to be restated to reflect the original intentions of the parties as nearly as possible in accordance with applicable law.

[THE REMAINDER OF THIS PAGE INTENTIONALLY LEFT BLANK]

**IN WITNESS WHEREOF**, the parties hereto have executed this Performance Agreement as of the date first written above.

**COUNTY OF RUSSELL, VIRGINIA**

By \_\_\_\_\_  
Name: \_\_\_\_\_  
Title: \_\_\_\_\_  
Date: \_\_\_\_\_

**INDUSTRIAL DEVELOPMENT  
AUTHORITY OF THE COUNTY OF  
RUSSELL, VIRGINIA**

By \_\_\_\_\_  
Name: \_\_\_\_\_  
Title: \_\_\_\_\_  
Date: \_\_\_\_\_

**RAMBLER STAVES, LLC dba  
RAMBLER WOOD PRODUCTS**

By \_\_\_\_\_  
Name: \_\_\_\_\_  
Title: \_\_\_\_\_  
Date: \_\_\_\_\_

APPENDIX A

Purchases of Virginia-grown Products:

**VIRGINIA AGRICULTURE PURCHASE PROJECTIONS**

<b>PROJECTED AGRICULTURE PURCHASES</b>								
	Year 1 \$ Value	Year 1 Volume (BF)	Year 2 \$ Value	Year 2 Volume (BF)	Year 3 \$ Value	Year 3 Volume (BF)	Net New \$ Value	Net New Volume (BF)
Total Ag Products Purchase	\$8,044,244	4,731,908	\$16,088,489	9,463,817	\$16,410,259	9,653,094	\$40,452,992	23,848,819
Timber (BF)	\$8,044,244	4,731,908	\$16,088,489	9,463,817	\$16,410,259	9,653,094	\$40,452,992	23,848,819
Total Virginia Ag Products Purchase	\$4,424,334	2,602,550	\$8,848,669	5,205,099	\$9,025,642	5,309,201	\$22,298,646	13,116,850
Timber (BF)	\$4,424,334	2,602,550	\$8,848,669	5,205,099	\$9,025,642	5,309,201	\$22,298,646	13,116,850
Percentage Virginia-grown	55%	55%	55%	55%	55%	55%	55%	55%

\*Timber purchases include full tracts with a variety of species including White Oak, Red Oak, other Virginia hardwoods, pulpwood, etc.

## APPENDIX B

### Break-Even Point Definition:

VDACS has estimated that the Commonwealth will reach its “break-even point” by the Performance Date. The break-even point compares new revenues realized as a result of the Capital Investment and New Jobs at the Facility with the Commonwealth’s expenditures on incentives, including but not limited to the AFID Grant.



**EXECUTIVE SECRETARY**  
KARL R. HADE

**ASSISTANT EXECUTIVE SECRETARY &  
LEGAL COUNSEL**  
EDWARD M. MACON

**COURT IMPROVEMENT PROGRAM**  
SANDRA L. KARISON, DIRECTOR

**EDUCATIONAL SERVICES**  
CAROLINE E. KIRKPATRICK, DIRECTOR

**FISCAL SERVICES**  
BARRY M. WENZIG, DIRECTOR

**HUMAN RESOURCES**  
RENÉE FLEMING MILLS, DIRECTOR

## SUPREME COURT OF VIRGINIA



OFFICE OF THE EXECUTIVE SECRETARY  
100 NORTH NINTH STREET  
RICHMOND, VIRGINIA 23219-2334  
(804) 786-6455

**JUDICIAL INFORMATION TECHNOLOGY**  
MICHAEL J. RIGGS, SR., DIRECTOR

**JUDICIAL PLANNING**  
CYRIL W. MILLER, JR., DIRECTOR

**JUDICIAL SERVICES**  
PAUL F. DELOSH, DIRECTOR

**LEGAL RESEARCH**  
STEVEN L. DALLE MURA, DIRECTOR

**LEGISLATIVE & PUBLIC RELATIONS**  
KRISTI S. WRIGHT, DIRECTOR

**MAGISTRATE SERVICES**  
JONATHAN E. GREEN, DIRECTOR

August 3, 2021

Ms. Missy Carter  
Russell County Drug Court Coordinator  
89 E. Main Street, Suite B  
P. O. Box 417  
Lebanon, VA 24266

**Supreme Court of Virginia Drug Treatment Court Docket Grant,  
Title: Russell County Adult Drug Treatment Court**

Dear Ms. Carter:

I am pleased to advise you that your grant for the above-referenced grant program has been approved for \$90,000 in State funds for fiscal year 2022. Please note the special condition prior to accepting this award.

Enclosed you will find a Statement of Grant Award and a Statement of Grant Award Special Conditions. To indicate your acceptance of the award and conditions, please sign the award acceptance and return it to Courtney Stewart, Specialty Dockets Grants Management Analyst, at the Office of the Executive Secretary (OES). Please review the conditions carefully as they require action on your part before we will disburse grant funds. Prior to the OES disbursing of funds, the Subrecipient must agree to comply with the following and the attached special conditions:

- a. Submit the quarterly grant reports by their due date to the Statewide Drug Treatment Court Coordinator.
- b. Maintain accurate & current data in the new web-based drug treatment court database beginning July 1, 2012.
- c. Submit a copy of any final federal grant report(s) and/or quarterly reports of any drug court Federal grant funds awarded.

When we receive documentation showing that you have complied with the conditions, you will be eligible to request funds awarded under this grant. A **REQUEST FOR FUNDS** form is also included with this letter and should be used for this purpose.

Russell County Adult Award Letter  
August 3, 2021  
Page Two

You may request funds at the same time you submit the documentation of compliance with the grant conditions or at any time thereafter. However, we cannot process your request until we have received and approved all required information.

We appreciate your interest in this grant program and will be happy to assist you in any way we can to assure your project's success. If you have any questions, please call Courtney Stewart at 804-356-1064.

Yours very truly,



Paul F. DeLosh

PFD/ces  
Enclosures

cc: Mr. Lonzo Lester, Russell County Administrator  
Ms. Alisha McGlothin, Russell County Treasurer  
Karl R. Hade, Executive Secretary  
Anna Powers, Drug Treatment Court Coordinator

**Supreme Court of Virginia**  
**Office of the Executive Secretary**

100 North Ninth Street Richmond, VA 23219

**Statement of Grant Award/Acceptance**

<b>Subrecipient--</b> Russell County Drug Court	<b>Date:</b> August 3, 2021
<b>Grant Period--</b> <b>From:</b> 7/1/2021	<b>Through:</b> 6/30/2022

Project Director	Project Administrator	Finance Officer
<b>Missy R. Carter</b> Drug Court Coordinator 135 Highland Drive P.O. Box 417 Lebanon, Virginia 24266 Phone No: (276) 889-8158 Email: <a href="mailto:missy.carter@russellcountyva.us">missy.carter@russellcountyva.us</a>	<b>Lonzo Lester</b> Russell County Administrator 137 Highland Drive P.O. Box 1208 Lebanon, Virginia 24266 Phone No: (276) 889-8000 Email: <a href="mailto:lonzolester@russellcountyva.us">lonzolester@russellcountyva.us</a>	<b>Alisha McGlothlin</b> Russell County Treasurer 137 Highland Drive P.O. Box 121 Lebanon, Virginia 24266 Phone No: (276) 889-8028 Email: <a href="mailto:rctreas@bvunet.net">rctreas@bvunet.net</a>

**GRANT AWARD BUDGET**

Budget Categories	Program Funds TOTALS
<b>A. Personnel</b>	\$ 51,750
<b>B. Consultants</b>	\$ 25,400
<b>C. Travel</b>	\$ -0-
<b>D. Equipment</b>	\$ -0-
<b>E. Indirect Expenses</b>	\$ -0-
<b>F. Supplies &amp; Other Expenses</b>	\$ 8,850
<b>TOTALS</b>	\$ 90,000.00

This grant is subject to all rules, regulations, and criteria included in the grant application and the special conditions attached thereto.



Paul F. DeLosh, Director of Judicial Services

The undersigned, having received the Statement of Grant Award/Acceptance and the Conditions attached thereto, does hereby accept this grant and agree to the conditions pertaining thereto, this 3<sup>rd</sup> day of August 2021.

Signature: \_\_\_\_\_

Title: \_\_\_\_\_

## STATEMENT OF GRANT AWARD SPECIAL CONDITIONS

Supreme Court of Virginia  
Office of the Executive Secretary  
Judicial Services Department  
100 North Ninth Street  
Richmond, Virginia 23219

### For the Supreme Court of Virginia Drug Treatment Court Grant to Localities

**Subrecipient: Russell County**

**Title: Russell County Adult Drug Court**

**Date: August 3, 2021**

The following conditions are attached to and made a part of this grant award:

1. By signing the Statement of Grant Award/Acceptance, the grant recipient agrees:
  - to use the grant funds to carry out the activities described in the grant application, as modified by the terms and conditions attached to this award or by subsequent amendments approved by the OES;
  - to adhere to the approved budget contained in this award and amendments made to it in accord with these terms and conditions;
  - and to comply with all terms, conditions and assurances either attached to this award or submitted with the grant application.
2. The subrecipient agrees to submit such reports as requested by the OES on forms provided by the OES. Funds from this grant will not be disbursed, if any of the required Financial or Progress reports are overdue by more than 30 days unless you can show good cause for missing the reporting deadline.
3. Grant funds, including local match, may be expended and/or obligated during the grant period. All legal obligations must be liquidated no later than 60 days after the end of the grant period. The grant recipient agrees to supply a final grant financial report and return all received and unexpended grant funds (exclusive of local match) to the OES within 60 days after the end of the grant liquidation period.
4. By accepting this grant, the recipient assures that funds made available through it will not be used to replace state or local funds that would, in the absence of this grant, be made available for the same purposes.
5. Subrecipient may follow their own established travel rates if they have an established travel policy. If a subgrantee does not have an established policy, then they must adhere to state travel policy. The state allows reimbursement for actual reasonable expenses. The state allows \$0.58 per mile for mileage. Transportation costs for air and rail must be at coach rates.
6. Within 60 days of the starting date of the grant, the subgrantee must initiate the project funded. If not, the subgrantee must report to the OES, by letter, the steps taken to initiate the project, the reasons for the delay, and the expected starting date. If the project is not operational within 90 days of the start date, the subgrantee must obtain approval in writing from the OES for a new implementation date or the OES may cancel and terminate the project and redistribute the funds.

7. **No amendment to the approved budget may be made without the prior written approval of OES. No more than two (2) budget amendments will be permitted during the grant period. Budget amendments must be requested using the enclosed budget amendment request form accompanied with a narrative. No budget amendments will be allowed after Friday April 15, 2022.**
8. The subrecipient agrees to forward a copy to the OES of the scheduled audit of this grant award.
9. All purchases for goods and services must comply with the Virginia Public Procurement Act. Procurement transactions, whether negotiated or advertised and without regard to dollar value, shall be conducted in a manner to provide maximum open and free competition. An exemption to this regulation requires the prior approval of the OES and is only given in unusual circumstances. Any request for exemption must be submitted in writing to the OES. Permission to make sole source procurements must be obtained from the OES in advance.
10. Acceptance of this grant award by the local government applicant constitutes its agreement that it assumes full responsibility for the management of all aspects of the grant and the activities funded by the grant, including assuring proper fiscal management of and accounting for grant funds; assuring that personnel paid with grant funds are hired, supervised and evaluated in accord with the local government's established employment and personnel policies; and assuring that all terms, conditions and assurances—those submitted with the grant application, and those issued with this award—are complied with.
11. Any delegation of responsibility for carrying out grant-funded activities to an office or department not a part of the local government must be pursuant to a written memorandum of understanding by which the implementing office or department agrees to comply with all applicable grant terms, conditions and assurances. Any such delegation notwithstanding, the applicant acknowledges by its acceptance of the award its ultimate responsibility for compliance with all terms, conditions and assurances of the grant award.
12. **PROJECT INCOME:** Any funds generated as a direct result of the OES grant funded projects are deemed project income. Project income must be reported on forms provided by the OES. The following are examples of project income: Service fees; Client fees; Drug test fees; Usage or Rental fees; sales of materials; income received from sale of seized and forfeited assets (cash, personal or real property included).
13. **Prior to the OES disbursing funds,** the Subgrantee must comply with the following special conditions:

**Law enforcement officers can be hired at their regular rate, not off-duty rate for active law enforcement. Consider contracting with a part-time retired law enforcement officer for this position or other who will perform these duties as regular rate. The approved surveillance officer rate is \$15.75.**

**Please provide additional information regarding the process group facilitator position.**

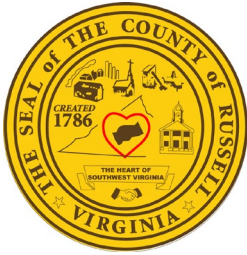

## **PUBLIC NOTICE**

### **REQUEST FOR QUALIFICATIONS (RFQ)**

#### **Professional Consulting Services**

The County of Russell is currently seeking professional services from qualified and experienced firms/consultants to provide environmental, engineering, and planning services to support the County's Three Rivers Destination Center Brownfields Assessment Project. To be considered for selection, consultants should have documented experience in providing brownfields-related consulting services associated with projects funded by EPA, DEQ, and other grants.

Firms meeting the requirements of this RFQ are invited to submit their proposal. Request for Qualifications (RFQ) are available on the County's Website [Bid Postings • Russell County, VA • CivicEngage \(russellcountyva.us\)](#) or email [lonzo.lester@russellcountyva.us](mailto:lonzo.lester@russellcountyva.us) to request the RFQ.

Proposals are due no later than 3:00 p.m., Friday, September 10, 2021. Any proposals received after this deadline will be returned to the offeror unopened. The County reserves the right to reject any and all proposals.

#### **Scope of Service:**

- **Site Characterization and Assessment Activities:** Conduct Phase II Environmental Site Assessment (ESA) for the Three Rivers Destination Center Project. All documents shall be required to be prepared in accordance with the applicable federal, state, and industry standards.
- **Redevelopment Planning and Conceptual Drawings:** Complete site-specific cleanup and redevelopment planning documents, including site remediation work plans and conceptual redevelopment site plans.
- **Other Brownfield-Related Duties:** Conducting and completing other duties that may be required for a successful program but that have not been anticipated in this document.

Disadvantaged Business Enterprises (small or minority and/or women owned firms) are encouraged to submit proposals. MBE/WBE firms are encouraged to submit proposals.

The County is an equal opportunity/affirmative action employer and will not discriminate based on race, creed, color, national origin, age, or handicap.

**BY ORDER OF THE  
RUSSELL COUNTY  
BOARD OF SUPERVISORS**



# COUNTY OF RUSSELL, VIRGINIA

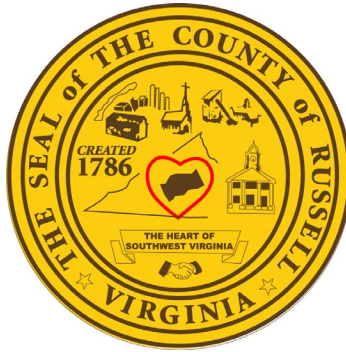

## Request for Qualifications (RFQ) Professional Consulting Services

Three Rivers Destination Center  
Brownfields Assessment Grant Project

Issue Date: August 30, 2021  
Due Date: September 10, 2021

COUNTY OF RUSSELL  
137 HIGHLAND DRIVE  
LEBANON, VA 24266  
276-889-8011

**Statement of Qualifications**  
Professional Consulting Services  
Three River Destination Center  
Brownfields Assessment Grant Project  
County of Russell, VA

**Introduction:**

The County of Russell is currently seeking professional services from qualified and experienced firms/consultants to provide environmental, engineering, and planning services to support the County's Three Rivers Destination Center Brownfields Assessment Project. In order to be considered for selection, consultants should have documented experience in providing brownfields-related consulting services associated with projects funded by EPA, DEQ, and other grants.

Specifically, the County has received funding for a Virginia Brownfields Assessment Fund (VBAF) project to perform environmental assessments on a specific project in the County.

**Scope of Service:**

Activities of the consultant shall include, but not necessarily be limited to, the following:

Environmental Assessment Project:

- **Site Characterization and Assessment Activities:** Conduct Phase II Environmental Site Assessment (ESA) for the Three Rivers Destination Center Project. All documents shall be required to be prepared in accordance with the applicable federal, state, and industry standards.
- **Redevelopment Planning and Conceptual Drawings:** Complete site-specific cleanup and redevelopment planning documents, including site remediation work plans and conceptual redevelopment site plans.
- **Other Brownfield-Related Duties:** Conducting and completing other duties that may be required for a successful program but that have not been anticipated in this document.

**Response Format:**

Submit one (1) original and one (1) electronic copy of the Statement of Qualifications (SOQ). The submittal shall be no longer than 12 pages (including organizational chart) and shall include the information outlined below. To ensure fair and equitable evaluation, proposals should be organized into the following separate sections:

- **Statement of Interest**  
The County intends to select one qualified consultant to perform the work.

- Experience and Capacity  
The SOQ shall include a description of the firm’s experience and capacity in providing the services as described herein;
  - Brownfields grant application writing and grant administration;
  - Brownfields project experience (EPA, DEQ, and private Brownfields experience);
  - Description of the firm's organizational structure and the names and experience of key individuals that would be assigned to this project, including professional registrations, site investigations, and experience working with the EPA and VDEQ; and,
  - Experience in site reuse planning/assessments and successful projects.
- Proposed Technical Approach and Understanding of Scope of Work  
The SOQ shall include a description of the approach the firm will take to complete the scope of work described herein. Include a description of the specific tasks that will be provided by your firm and the timing of how your firm proposes to undertake the work. Also, please address the role and responsibilities of County staff in this project, and whether there would be any out-of-pocket expenses for the County.
- References  
The SOQ shall include at least three (3) references for similar services/projects that have been provided by your firm and the dates of service. Please include the reference name, company, email address and phone number. Also include a description of the services and key personnel that were involved in the project.
- Conflict of Interest  
Please disclose any potential conflicts of interest.

Selection Criteria

Responses will be evaluated on the following criteria:

- Experience and ability to complete the work - 35 points
- Demonstrated brownfields experience including successful grant writing and administration - 20 points
- Technical approach and understanding of the scope of work - 20 points
- Quality of performance on Brownfields projects - 15 points
- Billing rates – 10 points

All SOQ’s must be received by 3:00 pm on September 10, 2021. Responses must be sealed and clearly marked on the outside mailing envelope – “Three Rivers Destination Center Brownfields Assessment Project”. Please mail or deliver to: County Administrator Office, 137 Highland Drive, P.O. Box 1208, Lebanon, VA. 24266

Prior to award, an oral presentation to the County may be requested. The request for an oral presentation shall in no way constitute acceptance or imply that an agreement is pending. The County reserves the right to award this opportunity based on the initial SOQ response without oral presentations.

### Award of Contract

In accord with the Code of Virginia §2.2-4302.2, the County shall engage in individual discussions with two or more firms deemed fully qualified, responsible, and suitable, based on the initial responses and with emphasis on professional competence to provide the required services. At the conclusion of these discussions, based on the evaluation factors published in the request for qualifications, the County shall select in the order of preference two or more firms whose professional qualifications and proposed services are deemed most meritorious.

Negotiations shall then be conducted, beginning with the offerors ranked first. If a contract or contracts satisfactory and advantageous to the County can be negotiated, the awards shall be made to that firm or firms. Otherwise, negotiations with the firm or firms ranked first shall be formally terminated and negotiations conducted with the offerors ranked second, and so on until such a contract can be negotiated.

Should the County determine in writing and in its sole discretion that only one or two firms are fully qualified, or that one or two firms are clearly more highly qualified than the others under consideration, a contract or contracts may be negotiated and awarded to that firm. Firms not selected shall be notified in writing.

The County may cancel this Request for Qualifications or reject all submissions at any time prior to an award.

### Contact Information:

Questions should be submitted in writing to the Lonzo Lester, County Administrator, by email to [lonzo.lester@russellcountyva.us](mailto:lonzo.lester@russellcountyva.us).

## GENERAL TERMS AND CONDITIONS

1. Proposals shall be submitted at the place and time specified in the RFQ advertisement. Submit the proposal in a sealed envelope. Identify the envelope with project name "*Three Rivers Destination Center Brownfields Assessment Project*" and the name and address of Offeror. No responsibility will be attached to any Officer or Agent for the premature opening of a proposal not properly addressed and identified.
2. It is the responsibility of the Offeror to assure that the proposal is delivered to the place designated for receipt of proposals prior to the closing time set for receipt of proposal. No proposal received after the time designated shall be considered. The Officer or Agent, whose duty it is to accept the proposals, will decide when the specified time has arrived.
3. If any respective Offeror has questions about the specifications or other solicitation documents, the prospective Offeror should contact the department which is named on the face of the solicitation no later than five (5) working days before the due date. Any revisions to the solicitation will be made only by addendum issued by the County.
4. Offerors are advised that oral explanations or instructions given by County Personnel during the Request for Proposals process, or at any time prior to the award shall be nonbinding.
5. Persons intending to submit a proposal are specifically cautioned that the Offeror is barred from pleading misunderstanding or deception because of estimates of quantities, character, location or other conditions surrounding the same.
6. Modifications, additions or changes to the Terms and Conditions of this Request by the Offeror may be cause for rejection.
7. Any proposal in response to this solicitation shall be valid for 90 days. At the end of the 90 days the proposal may be withdrawn at the written request of the Offeror. If the proposal is not withdrawn at that time, it remains in effect until an award is made or the solicitation is cancelled.
8. Payment for completed approved service will be made within thirty (30) days upon receipt of the invoice. The County of Russell has the right to verify information contained on any invoice and extend the time of payment until information is received to correct any errors found therein.
9. Unless otherwise provided in this solicitation, the name of a certain brand, make or manufacturer does not restrict Offerors to the specific brand, make or manufacturer named, but conveys the general style, type, character, and quality of the article desired.
10. Failure to furnish adequate data for evaluation purposes may result in declaring a proposal nonresponsive. Unless the Offeror clearly indicates the product offered is an equal product, such proposal will be considered to offer the brand name product referenced in the solicitation.
11. In the case of default by the successful Offeror or failure to deliver goods ordered by the time specified, the County, after due written notice, may procure them from other sources and hold Offeror responsible for any resulting additional purchase and administrative costs.

12. By submitting their proposals, Offerors certify that their proposals are made without collusion or fraud and that they have not offered or received any kickbacks or inducements from any other Offeror, supplier, manufacturer or subcontractor in connection with their proposal, and that they have not conferred on any public employee having official responsibility for this procurement transaction any payment, loan, subscription, advance, deposit of money, services or anything of more than nominal value, present or promised unless consideration of substantially equal or greater value was exchanged.

13. By submitting their proposal, Offerors certify to the County that they will conform to the provisions of the Federal Civil Rights Act of 1964, as amended, as well as the Virginia Fair Employment Contracting Act of 1975, as amended, where applicable, the Virginians with Disabilities Act, The Americans with Disabilities Act and §2.2-4311 of the Virginia Public Procurement Act.

14. By submitting their bid, the bidder certifies that they do not and will not during the performance of this contract employ illegal alien workers or otherwise violate the provisions of the federal Immigration Reform and Control Act of 1986.

15. During the performance of this contract, the contractor agrees as follows: (This section shall apply to all contracts over \$10,000)

- a. The contractor will not discriminate against any employee or applicant for employment because of race, religion, color, sex, or national origin, or disabilities, except where religion, sex or national origin is a bona fide occupational qualification reasonably necessary to the normal operation of the contractor. The contractor agrees to post in conspicuous places, available to employees and applicants for employment, notices setting forth the provisions of this nondiscrimination clause.
- b. The contractor, in all solicitations or advertisements for employees placed by or on behalf of the contractor, will state that such contractor is an equal opportunity employer.
- c. Notices, advertisements and solicitations placed in accordance with federal law, rule or regulation shall be deemed sufficient for the purpose of these requirements.

16. The contractor shall include the above provisions in every subcontract or purchase order over \$10,000, so that the provisions will be binding upon each subcontractor or vendor.

17. By submitting their proposal, the Offeror certifies that they do not and will not during the performance of this contract employ illegal alien workers or otherwise violate the provisions of the federal Immigration Reform and Control Act of 1986.

18. During the performance of this contract, the contractor agrees to (i) provide a drug-free workplace for the contractor's employees; (ii) post in conspicuous places, available to employees and applicants for employment, a statement notifying employees that the unlawful manufacture, sale, distribution, dispensation, possession, or use of a controlled substance or marijuana is prohibited in the contractor's workplace and specifying the actions that will be taken against employees for violations of such prohibition; (iii) state in all solicitations or advertisements for employees placed by or on behalf of the contractor that the contractor maintains a drug-free

workplace; and (iv) include the provisions of the foregoing clauses in every subcontract or purchase order of over \$10,000, so that the provisions will be binding upon each subcontractor or vendor.

19. By submitting their proposals, Offerors certify that they are not currently debarred by the Commonwealth of Virginia from submitting proposals on contracts for the type of goods covered by the solicitation, nor are they an agent of any person or entity that is currently debarred.

20. The County may make such reasonable investigations as deemed proper and necessary to determine the ability of the Offeror to perform the services and the Offeror shall furnish to the County all such information and data for this purpose as may be requested. The County reserves the right to inspect Offeror's physical facilities prior to award to satisfy questions regarding the Offeror's capabilities. The County further reserves the right to reject any proposal if the evidence submitted by, or investigations of, the Offeror fails to satisfy the County that such bidder is properly qualified to carry out the obligations of the contract.

21. Upon award of a contract, it shall not be assignable by the contractor in whole or in part without the written consent of the County.

22. Changes to the contract can be made in any of the following ways:

a. The parties may agree in writing to modify the scope of the contract. An increase or decrease in the price of the contract resulting from such modification shall be agreed to by the parties as a part of their written agreement to modify the scope of the contract.

b. The County may order changes within the general scope of the contract at any time by written notice to the contractor. Changes within the scope of the contract include, but are not limited to, things such as services to be performed, the method of packing of shipment, and the place of delivery or installation. The contractor shall comply with the notice upon receipt. The contractor shall be compensated for any additional costs incurred as the result of such order and shall give the County a credit for any savings. Compensation shall be determined by one of the following methods:

1. By mutual agreement between the parties in writing; or
2. By agreeing upon a unit price or using a unit price set forth in the contract; or
3. By ordering the contractor to proceed with the work and keep a record of all costs incurred and savings realized. A markup for overhead and profit may be allowed if provided by the contract. The same markup shall be used for determining a decrease in price as the result of savings realized. The contractor shall present the County with all vouchers and records of expenses incurred and savings realized.

23. The County reserves the right to reject any or all proposals, in whole or in part, to make separate awards, to waive informalities and to delete items prior to making the award, whenever it is deemed in the sole opinion of the County to be in its best interest. Due consideration will be given to price, previous experience and the ability of the Offeror to render required services.



24. The County shall not discriminate against any bidder, Offeror, or contractor in the solicitation or award of this contract because of race, religion, color, sex, national origin, age, disability, faith-based organizational status, any other basis prohibited by state law relating to discrimination in employment, or because the bidder or Offeror employs ex-offenders unless the County has made a written determination that employing ex-offenders on the specific contract is not in its best interest.

25. Cancellation of Contract -The County reserves the right to cancel any resulting contract, in part or in whole, without penalty, upon 30 days written notice to the Offeror. Any contract cancellation notice shall not relieve the Offeror of the obligation to deliver and/or perform on all outstanding orders prior to the date of cancellation.

26. Availability of Funds -It is understood and agreed between the parties that the County shall be bound only to the extent of the funds available, or which may become available for the purpose of this agreement.

27. Insurance Requirements:

a) Indemnification - The Offeror agrees, to the fullest extent of the law, to indemnify and hold the County harmless from and against all losses, damages, injuries, claims and demands whatsoever, regardless of the case thereof, and expenses in connection therewith, including reasonable counsel fees arising out of or incidental to the performance of the Offeror's duties and responsibilities under any agreement that results from this request for proposals. This covenant of indemnity shall continue notwithstanding any revocation or termination of any agreement that results from this request for proposals. The Offeror shall be given prompt notice of any claims, demands or causes of action, and reasonable opportunity to defend the same.

b) Insurance - The Offeror shall secure and keep in force, at its sole cost and expense, the following insurance policies which shall be in form and content satisfactory to the County and shall be issued by insurance companies qualified to do business in the Commonwealth of Virginia.

Property Damage and Liability Insurance - Policy of property damage and public liability insurance which shall protect the County and such other persons as the County shall designate against any liability imposed by law upon the County, the Offeror, or both. Coverage shall include damages for loss of or damages to property, or for bodily injuries, including death suffered or claimed by reason or in consequence of any act or omission of any act by an employee or agent of the Offeror. Such insurance shall be on a comprehensive General Liability form with limits of \$1,000,000 each occurrence, \$1,000,000 aggregate and bodily injury liability to include: premises operations products, complete operations, contractual and broad form property damage.

Worker's Compensation and Other Insurance - The Offeror shall carry such Worker's Compensation Insurance and other insurance on its employees and agent performing services under this contract, as is required by the Code of Virginia.

c) Upon award, the Offeror shall provide the County with a certificate of insurance. Policy coverage shall be maintained during the entire term of the contract.



# COMMONWEALTH of VIRGINIA

## Department of Criminal Justice Services

Shannon Dion  
Director

Megan Peterson  
Chief Deputy Director

Washington Building  
1100 Bank Street  
Richmond, Virginia 23219  
(804) 786-4000  
[www.dcjs.virginia.gov](http://www.dcjs.virginia.gov)

July 30, 2021

Lonzo Lester  
Russell County County Administrator  
137 Highland Drive  
Lebanon, Virginia 24266

RE: Russell County Victim/ Witness Assistance Program

Dear Lonzo Lester:

Congratulations on being a recipient of the above referenced grant program! Your DCJS grant award number is **22-O1108VW19** and was approved for a total award of **\$70,000**, funded through Award Numbers **2019-V2-GX-0054 and 2020-V2-GX-0048**. The project period is **7/1/2021 through 6/30/2022**.

Included with this letter is a Statement of Grant Award/Acceptance (SOGA). Please note hard copies of the General Special Conditions, as well as the Reporting Requirements and Projected Due Dates, are now referred to as **Conditions and Requirements** and will be posted online at <https://www.dcjs.virginia.gov/grants/grant-requirements> within the next two weeks.

In addition to the general Special Conditions, there may be grant specific Special Conditions related to your Grant Award called Encumbrances. If there are any, you are required to adhere to these conditions via the On-line Grants Management System (OGMS) at <https://ogms.dcjs.virginia.gov/>. If you have not previously done so, you must register in order to use this web-based system. The instructions on *Registering for a New Account* and *Submitting Action Item Encumbrances* are posted here <https://www.dcjs.virginia.gov/grants/ogms-training-resources> along with other resources.

We will be happy to assist you in any way we can to assure your project's success. To indicate your acceptance of the award and conditions, please sign the included SOGA and return it electronically within the next 60 days to [grantsmgmt@dcjs.virginia.gov](mailto:grantsmgmt@dcjs.virginia.gov). If you have questions, contact your DCJS Grant Monitor **Patricia Foster** at **804-371-8634** or via email at [Patricia.Foster@dcjs.virginia.gov](mailto:Patricia.Foster@dcjs.virginia.gov).

Sincerely,

A handwritten signature in blue ink that reads "Shannon Dion".  
Shannon Dion

## STATEMENT OF GRANT AWARD (SOGA)

Virginia Department of Criminal Justice Services  
1100 Bank Street, 12<sup>th</sup> Floor  
Richmond, Virginia 23219

### Russell County Victim/ Witness Assistance Program

Subgrantee: Russell  
DUNS Number: 40157851                      DCJS Grant Number: 22-O1108VW19  
Grant Start Date: 7/1/2021                      Grant End Date: 6/30/2022

Indirect Cost Rate:            %            \*If applicable

Federal Grant Number:            2019-V2-GX-0054 and 2020-V2-GX-0048  
Federal Awardee:                      OVC  
Federal Catalog Number:            16.575  
Project Description:                To provide direct services for crime victims.  
Federal Start Date:                    10/1/2018

Federal Funds:                        **\$49,000**  
State General Funds:  
State Special Funds:                **\$21,000**  
  
Total Budget:                         **\$70,000**

Project Director	Project Administrator	Finance Officer
Casie Hess Victim Witness Director 53 E. Main Street Lebanon, Virginia 24266 276-889-8225 casie@russellcountyca.com	Lonzo Lester Russell County County Administrator 137 Highland Drive Lebanon, Virginia 24266 276-889-8000 lonzo.lester@russellcountyva.us	Alicia McGlothlin Russell County Treasurer 137 Highland Drive Lebanon, Virginia 24266 276-889-8028 alicia.mcglathlin@bvua.net

**\*Please indicate your ICR in the space provided, if applicable.** As the duly authorized representative, the undersigned, having received the Statement of Grant Awards (SOGA) and reviewing the Special Conditions, hereby accepts this grant and agree to the conditions and provisions of all other Federal and State laws and rules and regulations that apply to this award.

Signature: \_\_\_\_\_

Authorized Official (Project Administrator)

Title: \_\_\_\_\_

Date: \_\_\_\_\_



Corporate Office: 3475 Ashley Road, Montgomery, AL 36108  
South Carolina Office: 115 Belvedere Circle, West Columbia, SC 29172  
Phone: 334.264.3265; Fax 334.269.6990

July 14, 2021

Russell County Virginia Board of Supervisors  
P.O. Box 1208  
Lebanon, VA 24266  
Phone : 276-415-9102  
E mail: brian.ferguson@russellcountyva.us

Re: Proposed Auction

We want to thank you for allowing J.M. Wood Auction Company, Inc. the opportunity of submitting a proposal on the auction of your surplus equipment. Since 1973, J.M. Wood Auction Co. Inc. has conducted thousands of public auctions and sold billions of dollars of heavy machinery and trucks to buyers across the world. We believe our marketing methods along with our extensive global reach to buyers are necessary for you to achieve the true global market value of your assets.

- ❖ **Auction Location and Date:** The proposed auction will be September 21 - 23, 2021 at our one-hundred-acre permanent auction facility in Montgomery, Alabama.
- ❖ **Traditional Auction Marketing:** J.M. Wood Auction will promote and feature your equipment in our full color auction magazine. A personalized mailing list will be selected from our database of over 100,000 domestic and international buyers. We will select potential buyers to market to by targeting recent buying patterns, trending industries, and regional activity. Your auction will be promoted in numerous industry specific trade magazines as well as in over (300) newspapers reaching a broad range of potential buyers.
- ❖ **Online Auction Marketing:** Our team will go to work immediately posting your inventory with multiple photos and inspections on JMWood.com. Our website is an essential tool in reaching thousands of buyers who visit our site daily. Your inventory will also be posted on numerous worldwide industry related sites in front of millions of buyers searching for equipment for their operations in countries across the globe. Your equipment will also be featured in J.M. Wood Auction's award-winning social media marketing campaign consisting of outlets such as Face book, Twitter, YouTube and more. Both Facebook and Constant Contact have recognized J.M. Wood Auction as one of their annual top performing marketing companies.
- ❖ **Auction Delivery, Pre-Auction Services and Set Up:** We encourage you to schedule delivery of your equipment to the auction facility as soon as possible. This allows adequate time for pre-auction services such as detailed inspection reports, photography, video, clean-up, and repairs. J.M. Wood Auction will provide the seller with a detailed report on any

repairs and clean-up deemed necessary to make the equipment bring the maximum dollar. No repairs will be made without prior consent from seller. J.M Wood Auction will coordinate an on-site detailed clean-up service on the equipment listed on the sellers (Exhibit "A"). J.M. Wood Auction will have representatives aggressively marketing your equipment and answering questions from prospective buyers prior to the auction.

- ❖ **Auction Day:** With over 40 years in the auction business, it is in our blood. We live for auction day, and it is exciting! When you arrive at one of our world class drive through auction facilities you will find a team of professionals that know and love their job. A detailed auction catalog with lot numbers will be presented to all the pre-approved buyers on hand. The equipment will be paraded past the auction theatre full of attendees and broadcast live on the internet as well. We will furnish all personnel to conduct the auction, collect proceeds, and assist in load-out.
- ❖ **Online Auction Bidding:** JMWoodLive.com is our exclusive proprietary online bidding service. Since its inception, we have registered tens of thousands of pre-approved national and international buyers. Multiple photos of the exterior, interior and components of every item will be posted for online buyers. In addition, we provide detailed inspection services on any equipment the prospective buyer may need.
- ❖ **Buyer Services:** Prior to the auction, J.M. Wood Auction provides the buyer with detailed inspection services, financing options and logistical estimates. After the auction, we will coordinate logistics as well as dismantle and containerize equipment headed to the port.
- ❖ **Post Auction and Payment Terms:** J.M. Wood Auction will furnish a computerized statement of each item sold. We will issue seller a check for full settlement within 10 banking days after the date of auction. Any service fees incurred such as clean-up, repairs, and transportation will be deducted from seller's final net proceeds.
- ❖ **Liens and Encumbrances:** Auctioneer acts as Sellers's agent. Seller guarantees that he/she is the sole owner of items being sold and states that items are free of all mortgage's liens and encumbrances. Seller agrees to disclose all specific liens, blanket liens, mortgages, taxes, encumbrances or claims of any sort and states he is not connected to claim by Bankrupt Court or IRS. In the event, such claim should exist Seller agrees to pay all legal expense incurred by Auctioneer to protect and defend clear title. Seller hereby authorizes J.M. Wood Auction Co., Inc (hereby known as Auctioneer) at the absolute discretion of Auctioneer to carry out title searches in respect of the equipment at the expense of Seller, but in no case, shall Auctioneer have a duty to conduct, nor be responsible for the results of any such title search.

## Proposal Options:

- ❖ **(Financial Guarantee)**
  - J.M. Wood Auction gives a NET financial guarantee of \$118,500.00 for the 2020 Mack GR64F T/A Roll Off Truck as per the specifications and conditions listed on the attached (Exhibit "A"). A commission rate of 7% Absolute will be charged to gross sales.

This Equipment needs to be on our yard no later than September 13, 2021.

We would like to thank you for allowing J.M. Wood Auction Company, Inc. to present this proposal to you and we look forward to conducting your auction.

## "We Turn Equipment into Cash"

  
\_\_\_\_\_  
Russell County VA Board of Supervisors

  
\_\_\_\_\_  
Date

  
\_\_\_\_\_  
Curt Brown, Territory Manager  
J.M. Wood Auction Co., Inc.

  
\_\_\_\_\_  
Date

  
\_\_\_\_\_  
John D. Gray, Vice President  
J.M. Wood Auction Co., Inc.  
*Kentucky Auctioneer's License # RP2876*  
*Alabama Auctioneer's License # 1791*

  
\_\_\_\_\_  
Date

*THIS DOCUMENT IS CONFIDENTIAL; IT CONTAINS PROPRIETARY INFORMATION THAT IS INTENDED ONLY FOR USE BY AUTHORIZED J.M. WOOD AUCTION CO., INC. REPRESENTATIVES AND AUCTIONEERS. THIS DOCUMENT MAY NOT BE COPIED OR SHARED WITH ANY PARTY OTHER THAN J.M. WOOD AUCTION CO., INC. UNAUTHORIZED USE IS STRICTLY PROHIBITED.*



"Exhibit A  
 Russell County Virginia  
 137 Highland Dr  
 Lebanon, VA 24266  
 Phone: 270-343-2112  
 E mail: brian.ferguson@russellcountyva.us  
 September 21 - 23, 2020 Auction in Montgomery, AL  
 Due Date: "July 14, 2021"



CATEGORY	YEAR	MAKE	MODEL	S/N	DESCRIPTION	HRS/MILES	CONDITION	REPAIRS REQUIRED
Roll Off Trucks	2020	Mack	GR64F	1M2GR3GC4LM016846	T/A, 415 HP Mack MP8 engine, Mack mDrive trans, 44K rears, 18K front, PS, AC, 60,000# Galbreath Hoist, Pioneer Tarp System, tool box, full fenders, 315/80R22.5 front tires, 11R22.5 rear tires, disc wheels	80,000	GOOD	clean-up

<b>Total Net Guarantee:</b>	<b>\$ 118,500.00</b>
<b>Commission Rate:</b>	<b>7%</b>
<b>Sale Date:</b>	<b>September 22 - 25, 2020</b>

Customer Initial  
 \* Must meet terms and conditions listed on Legal of this document.

JMW Initial

\*subject to legal terms that are attached.



## MONTHLY BANK BALANCES

July 31, 2021

Regular Account	5,065,395.26
Employee Insurance	4,288,828.02
Employee Claims Account	1,000.00
Non-Judicial Reals Estate Sales	3,145.64
Russell Co. Housing Fund	4,424.36
School Textbook	54,740.92
Sheriff Domestic Violence	1,372.39
Petty Cash Treasurer	866.70
Sheriff Seized Assets	58,672.21
Sheriff Restitution	7,655.60
Sheriff Forfeited Assets	33.70
Comm Attorney Forfeited Assets	31,713.14
Sheriff Federal Forfeited Assets	7,526.21
Comm Attorney Fed Justice Forfeited Assets	124,516.82
Commonwealth Attorney Abanoned Property	500.00
Sheriff Federal Justice Forfeited Assets	7,918.73
Sheriff Calendar Fund	0.00
Sheriff Special Projuects	38,422.14
SSI Recipients	1,400.17
First Sentinel Bank	1,000.00
Bank of Honaker	930.00
New Peoples Bank	1,000.00
Certificates of Deposit General	49,575.00
Treasurer's Money Market	3,069,651.74
Certificate of Deposit Library Donations	24,788.80
Certificate Of Deposit Employee Insurance	2,000,000.00
<b>Total Cash In Bank</b>	<b>14,845,077.55</b>
<b>Cash In Office</b>	<b>1,600.00</b>
<b>Petty Cash</b>	<b>100.00</b>
<b>TOTAL CASH</b>	<b>14,846,777.55</b>

ACCOUNT	DATE	July 31, 2021
	DEBIT	CREDIT
Cash in Office	1,600.00	
Cash in Bank	14,845,077.55	
Petty Cash	100.00	
General Fund		3,159,939.69
Non-Judicial Real Estate Sales		3,145.64
Sheriff In State Trip		30,861.95
Sheriff Dare Fund		100.00
Sheriff Seized Assets		58,672.21
Sheriff Restitution		7,655.60
Sheriff Forfeited Assets		33.70
Comm Attorney Forfeited Assets		31,713.14
Honaker Library Donations		24,783.87
Russell County Housing Fund		4,424.36
Sheriff Federal Forfeited Assets		7,526.21
Sheriff Domestic Violence		1,372.39
Comm Attorney Abandoned Prop		500.00
Comm Attorney Fed Justice		124,516.82
Sheriff Fed Justice Forfeited		7,918.73
Sheriff Calendar Fund		0.00
Sheriff's Special Projects		38,422.14
Social Services		(343,834.80)
Swva Asap		16,729.91
Coal Road Improvement		487,452.83
CSA		(461,773.37)
School Fund		1,309,953.59
School Food		1,164,883.36
School Textbook		54,740.92
Regional Adult Education		259,990.71
Petty Cash Treasurer		866.70
COVID 19		79,840.46
Litter Fund Trash Pickup		(23,206.85)
American Rescue Act		2,278,212.54
Current Credit		(0.79)
Current Debit		14.44
Title XX		11,321.05
SSI Recipients		1,400.17
Damage Stamp Fund		2,823.98
Valley Heights		79,860.39
Dante Sewer		53,706.00
Employee Health Insurance		4,288,828.02
Employee Insurance COD		2,000,000.00
Employee Insurance Claims		1,000.00
Law Library		59,148.51
Special Welfare		48,125.37
Housing Fund #2		7,700.00
Russell Co Health & Fitness		132,865.92
Cannery		(175,509.71)
WIB		10,051.75
<b>Total</b>	<b>14,846,777.55</b>	<b>14,846,777.55</b>

**July 8, 2021**

The Regular monthly meeting of the Industrial Development Authority of Russell County, Virginia was held on July 8, 2021, at 5:30 P.M. at the Russell County Conference Center.

**MEMBERS**

**PRESENT:** Ernie McFaddin, Chairman  
Carlton Elliott, Secretary  
Roger Sword, Member  
John Stamper, Member  
Donnie Christian, Member  
Tony Dodi, Member

**ABSENT:** Scott Gilmer, Member  
Jarred Glass, Member  
Richard Lockridge, Vice Chairman

**STAFF:** Katherine Patton, Attorney

The Chairman called the meeting to order at 5:32 P.M.

Secretary called the roll and recorded the roll call.

**APPROVAL OF MINUTES**

Upon motion made by Tony Dodi, second by Roger Sword and duly approved by the Industrial Development Authority of Russell County, Virginia to approve the minutes of the June 10, 2021 meeting.

The Vote was:

Aye: C. Elliott, R. Sword, J. Stamper, T. Dodi, D. Christian

Absent: S. Gilmer, J. Glass, R. Lockridge

Nay: None

**FINANCIAL REPORT**

Upon motion made by Donnie Christian, second by John Stamper, and duly approved by the Industrial Development Authority of Russell County, Virginia to approve the June 2021 financial reports and pay invoices presented.

The Vote was:

Aye: C. Elliott, R. Sword, J. Stamper, T. Dodi, D. Christian

Absent: S. Gilmer, J. Glass, R. Lockridge



Nay: None

### **PUBLIC/GUEST PRESENTATIONS**

No guest presentations.

### **ATTORNEY'S REPORT**

The attorney is working with Johnathan Belcher at VCEDA to close on the ACME building.

### **CHAIRMAN'S REPORT**

The IDA has a request for a letter of support from People Inc. for a grant to Poly Cap for equipment purchases.

Upon motion made by Roger Sword, second by Donnie Christian, and duly approved by the Industrial Development Authority of Russell County, Virginia to supply a letter of support to People Inc. for a grant to Poly Cap to purchase equipment.

The Vote was:

Aye: C. Elliott, R. Sword, J. Stamper, T. Dodi, D. Christian

Absent: S. Gilmer, J. Glass, R. Lockridge

Nay: None

The chairman reported the inside demo on the Russell Place is in progress.

The chairman presented the proposal from Sky Solar to place solar panels on the buildings owned by the IDA.

The chairman reported on the revolving loan program:

Beartown Crossfit has paid off their loan.

Honaker Wholesale is paying on schedule.

NexGen Welding Service has bought a truck with their loan proceeds.

J&J Trash Services is looking to take advantage of the loan program.

### **CLOSED SESSION**

Upon motion made by Donnie Christian, second by Roger Sword and duly approved by the Industrial Development Authority of Russell County, Virginia to enter Closed Session as permitted by, VA Code #2.2-3711 (3) Property (5) Prospective unannounced industry (7) & (8) Legal Counsel.

The Vote was:

Aye: C. Elliott, R. Sword, J. Stamper, T. Dodi, D. Christian  
Absent: S. Gilmer, J. Glass, R. Lockridge  
Nay: None

**RECONVENE TO PUBLIC SESSION**

Upon motion made by Tony Dodi, second by Donnie Christian, and duly approved by The Industrial Development Authority of Russell County, Virginia, the Chairman called the meeting back into regular session and requested the “Certification Motion after reconvening in Public Session”.

The Vote was:

Aye: C. Elliott, R. Sword, J. Stamper, T. Dodi, D. Christian  
Absent: S. Gilmer, J. Glass, R. Lockridge  
Nay: None

**CERTIFICATION AFTER RECONVENING IN PUBLIC SESSION**

The Industrial Development Authority of Russell County, Virginia hereby certifies that, in the closed session just concluded, nothing was discussed except the matter or matters (1) specifically identified in the motion to convene in closed session and (2) lawfully permitted to be so discussed under the provision of the Virginia Freedom of Information Act cited in that motion.

The Roll Vote Was:

Ernie McFaddin	Yes	Donnie Christian	Yes
Carlton Elliott	Yes	Jarred Glass	Absent
Scott Gilmer	Absent	John Stamper	Yes
Tony Dodi	Yes	Richard Lockridge	Absent
Roger Sword	Yes		

**MOTIONS FROM CLOSED SESSION**

Upon motion made by Donnie Christian, second by Tony Dodi, and duly approved by The Industrial Development Authority of Russell County, Virginia authorizing the attorney to send a letter to the owner of the Acme building, requesting the items be remove from the premises within 60 days and giving the attorney the authority to negotiate the terms.

The Vote was:

Aye: C. Elliott, R. Sword, J. Stamper, T. Dodi, D. Christian  
Absent: S. Gilmer, J. Glass, R. Lockridge  
Nay: None

Upon motion made by Roger Sword, second by John Stamper, and duly approved by The Industrial Development Authority of Russell County, Virginia adopting a resolution to ask the Russell County Board of Supervisors to reserve \$500,000.00 from the American Relief Plan Funds for industrial property acquisitions.

The Vote was:

Aye: C. Elliott, R. Sword, J. Stamper, T. Dodi, D. Christian

Absent: S. Gilmer, J. Glass, R. Lockridge

Nay: None

### **ADJOURNMENT**

Upon motion made by Donnie Christian, second by John Stamper, and duly approved by the Industrial Development Authority of Russell County, Virginia adjourning this meeting at 9:25 PM

The Vote was:

Aye: C. Elliott, R. Sword, J. Stamper, T. Dodi, D. Christian

Absent: S. Gilmer, J. Glass, R. Lockridge

Nay: None



**MINUTES OF THE MONTHLY BOARD OF DIRECTORS' MEETING**

MINUTES OF THE MONTHLY MEETING OF DIRECTORS of The Russell County Public Service Authority held at held at 137 Highland Drive Lebanon, VA 24266 on this 17th day of August 2021 at 6:00 PM.

1. The following members were present, constituting a quorum (4):  
Cuba Porter, Chairman;  
David Edmonds, Jr, Treasurer;  
Carter McGlothlin;  
Clifford Hess;  
Joe Huff; and  
Rhonda Lester, Secretary.
2. Also present:  
Harvey Hart, RCPSA Director  
James Baker, T&L;  
Rita Baker, T&L;  
Katie Patton, Legal Counsel; and  
Oris Christian
3. All the above directors of The Russell County Public Service Authority being present, formal notice calling the meeting was dispensed with, and the meeting declared to be regularly called.
4. Cuba Porter acted as Chairperson of the meeting and Rhonda Lester as Secretary of the meeting.
5. Harvey Hart opened the meeting with the Pledge of Allegiance followed by a prayer led by David Edmonds, Jr.
6. Approve Agenda –  
  
Motion to approve the agenda as read made by David Edmonds, Jr., seconded by Clifford Hess, and unanimously adopted.
7. Minutes of the last meeting dated July 20, 2021 were reviewed and, motion to approve as read made by Carter McGlothlin, seconded by Clifford Hess and unanimously adopted.
8. Public Comments:  
  
Oris Christian addressed the Board inquiring about payment status to CL Dale Construction for work performed on flood damage in Dante and Swords Creek; Harvey Hart advised that FEMA would be releasing the funds to the County for payment soon.
9. Harvey Hart, RCPSA Director, presented to the meeting:
  - Bank Activity and Account Balances Reports
  - Profit and Loss Reports
  - Outstanding Construction Receivables Report

Motion to adopt financial reports as presented made by Clifford Hess, seconded by Joe Huff and unanimously adopted.

10. Harvey Hart, RCPSA Director, presented to the meeting:

- Water Loss Reports

11. Rita Baker with Thompson & Litton presented to the meeting the following project updates from July 20, 2021 to date:

- BELFAST PH II

Installed 479 LF of ¾-inch line and (2) Meters. A progress meeting was held on 08/06/21. All that is needed for completion of this project is paving. A request letter was sent to DHCD to utilize the remaining funds to install an additional mile of line and pick up one additional customer.

- GLADE HOLLOW/GLADE HILL PROJECT

Installed (6) Service Meters, (1) Sample Station.

- ARTY LEE CAMPGROUND PROJECT

Placed gravel and decorative rock, installed electrical and water service and continued working on installation of sewer line across the ballfield. All that is needed for completion of this project is installation of sewer and road bore for sewer.

12. Old Business to Discuss:

a) Joe Huff inquired about the use of our Green Valley wells. He suggested that if we are not going to use them, then we need to do away with them. Harvey Hart advised that the reason we stopped using the wells is one of them pulled mud into the system at one point. He also advised that he was going to test putting the wells back into use this fall.

13. New Business to Discuss:

a) Motion to approve purchase of fire hydrant repair materials made by Carter McGlothlin, seconded by Clifford Hess, and unanimously adopted.

b) Cuba Porter appointed himself, David Edmonds, Jr, Harvey Hart, and Rhonda Lester to serve on a Budget Committee.

14. Matters presented by the Board:

Cuba Porter advised the Board that he and the County Administrator would work with the Town of Lebanon to try to renegotiate a water purchase agreement with lower rates.

15. Motion to go into executive session pursuant to VA code 2.2-3711 (A) (7) Consultation with legal counsel regarding Crossroads Engineering made by Joe Huff, seconded by David Edmonds, Jr., and unanimously adopted.

Motion made by Carter McGlothlin seconded by Joe Huff, and duly approved by the Board of Directors to return to regular session.

Pursuant to § 2.2-3712(D) of the Code of Virginia 1950, as amended each member of the Board of Directors upon the Roll Call certifies that to the best of their knowledge (I) only public business matters lawfully exempted from the open meeting requirements under the Virginia Freedom of Information Act and (ii) only such public business matters that were identified in the motion(s) by which the closed meeting was convened were heard, discussed or considered in the meeting by the Board of Directors.

Any member of the Board of Directors who believes that there was a departure from the requirements of clauses (I) and (ii) above shall so state prior to the vote, indicating the substance of the departure that, in his or her judgment, has taken place.

Are there any who believe a departure has taken place? Seeing none, if you agree that the matters heard, discussed, or considered during the closed meeting were pursuant only to the motion(s) by which the closed meeting was convened, please signify by saying aye or yes.

A roll call vote was taken.

Carter McGlothlin: Yes

Clifford Hess: Yes

Cuba Porter: Yes

Chris Dye: Absent

Joe Huff: Yes

Donnie Christian: Absent

David Edmonds, Jr.: Yes

Yes: 5

No: 0

Absent: 2

By a majority vote, motion to return to regular session was approved.

16. There being no further business to come before the meeting, a motion to adjourn at 7:23 PM was made by Carter McGlothlin seconded by David Edmonds, Jr., and adopted.

The next meeting is scheduled for September 21, 2021 at 6:00 PM.

Dated in the Commonwealth of Virginia on  
the 17th day of August 2021.

  
\_\_\_\_\_  
(Signature)

Secretary Name: Rhonda Lester



# RUSSELL COUNTY CONFERENCE CENTER

August 1, 2021

The following is a list of the Russell County Conference Center events for the month of August.

Date	Event	Event Type	Space
08/01/21	16 <sup>th</sup> Birthday Party Tina Trent	Individual Event	Full \$125
08/03/21	Drug Court Legal Aid Missy Carter	Individual Event	Full \$0
08/07/21	Household Shower Crystal Moore	Individual Event	Full \$125
0812/21	Growing Friends and Flowers Bingo Yvonne Dye	Community Event	Full \$135
08/14/21	Baby Shower Haley Mays	Individual Event	Full \$125
08/16/21	Mountain Movers Meeting Kevin Blankenship	Community Event	Full \$0

08/18/21	IDA Board Meeting Ernie McFadden	Community Event	Full \$0
08/19/21	Work Force Development Board Meeting Pam Ratliff	Individual Event	Full \$190
08/20/21	Birthday Party Janet Music	Individual Event	Full \$125
08/21/21	Russell County Farm Bureau Meeting Bruce Warner	Community Event	Quarter \$135
08/22/21	80 <sup>th</sup> Birthday Party Kelsey King	Individual Event	Full \$205
08/26/21	Metallurgical Coal Producers Association Seminar Barbara Altizer	Individual Event	Full \$460
08/28/21	Richlands High School 1971 Class Reunion Patricia Altizer	Individual Event	Full \$150

**(Total: \$2,150.00)**

- \$375.00

**Final Total = \$ 1,775.00**

THE RUSSELL COUNTY TRANSPORTATION AND SAFETY COMMISSION MET AT THE BONANZA RESTAURANT IN LEBANON VIRGINIA ON AUGUST 10TH 2021

**MEMBERS & GUEST PRESENT**

EUGENE FERGUSON LINDA CROSS MIKE O'QUINN GARY DOTSON  
TIM LOVELACE HENRY KINCER CARL RHEA JOHNNY JESSEE  
TONY MAXFIELD BARBARA COX HENRY STINSON

**GUARD RAILS CONTRACTOR BEHIND IN BRISTOL AREA**

- 1-GUARD RAILS REPLACED AS DAMAGED
- 2-RT 58E JUST BEYOND QUARRY ROAD A SECTION OF GURAD RAIL DAMAGED FROM A FALLEN TREE
- 3-RT 657 NEEDS GUARD RAIL INSTALLED 1/8 MILE SOUTH OF RT. 658 FIRST BRICK HOUSE ON THE LEFT CAUSED BY A WRECK
- 4-RT 80 DON STEVENS DR. GUARD RAIL DAMAGED BARTONS GARAGE SUBV.
- 5-RT 58/QUARRY RD IN CASTLEWOOD GUARD RAIL DAMAGED
- 6-RT- 58 CASTLEWOOD CROSS OVER AT THE PIZZA HUT DAMAGED
- 7-NEW GARDEN /CLEVELAND ROAD END OF GUARD RAIL DAMAGED. WILL MOVE RAIL BACK TO ALLOW BETTER TURNING RADIUS. **HAS BEEN TURNED IN**
- 8-RT 67 NEAR MILLER CREEK END SECTION OF GUARD RAIL TORN OFF  
**ALL GUARD RAILS HAVE BEEN REVIEWED AND TURNED IN**

**SHOULDER REPAIR AND POT HOLE**

- 1-RT 801 STEELE HOLLOW RD. OFF BOOKER HOLLOW NEEDS TO BE GRADED AND TREATED FOR DUST
- 2-RT 58W NEAR MILE MARKER 62.8 SIGN WARNING TO WATCH FOR FALLING ROCKS COVERED WITH KUDZU. **PUT ON SCHEDULE**
- 3-RT-58 WEST ACROSS FROM PIZZA HUT THE DITCH NEEDS TO BE PULLED AND THE PIPE CLEARED FOR A FASTER FLOW. THE WATER IS COMING UP IN THE ROADWAY DURING HEAVY RAIN THUS CAUSING A HAZARD CONDITION ESPECIALLY DURING FREEZING WEATHER. **PIPE TO BE CLEANED /VDOT**
- 4-RT 727 SCENIC ELK GARDEN WEEDS AND BRUSH COMING INTO ROADWAY. **HAS BEEN MOWED AND BRUSH TO BE CUT IN THE FALL**
- 5-Rt 615 Back Valley cracker neck area dips IN THE ROAD has been **patched will fix better in the spring being evaluated for permanent repairs. SLIDE ABOVE THE ROAD GETTIN WORSE. SCHEDULED FOR REPAIRS**



6-RT 65/611 INTERSECTION BRUSH BLOCKING VIEW PULLING OUT ONTO RT65  
7-RT 645/640 JESSEE MILL ROAD NEAR LONG HOLLOW ROAD IS BROKEN OFF.  
**UNDER REVIEW FOR REPAIR AND PERMITTING**

8-RT 67 MAPLE GAP A CURVE NEEDS A TRUCK ENTERING SIGNS INSTALLED AT A  
LOWER HEIGHT THAN NORMAL FOR BETTER VISIBILITY. **TURNED IN TO BRISTOL**

9-RT 682 DEAD AND LIVE TREES HANGING OVER THE ROAD FIRST MILE FROM RT  
609 AND BRUSH FROM FALLEN TREES LAYING ALONG THE ROADWAY NEAR THE  
TOP NEEDS TO BE REMOVED. GARY DOTSON SHOWED JEFF CAMPBELL FROM  
VDOT AND WE DISCUSSED THE CONCERNS. **UNDER REVIEW WITH JAMI**  
**PENNINGTON REMOVAL PENDING NEW CONTRACTOR**

10-RT 1080 NORTH CEDAR RUFF NEEDS TO BE PAVED. **WILL PATCH POT HOLES**  
**AND IS IN THE SYSTEM FOR PAVING**

11-RT 63 LARGE POT HOLE ON THE INSIDE OF A CURVE NEAR TRASH SITE ALSO  
RUFF CONDITION IN NORTH LANE FIRST CURVE BEYOND THE CLINIC. **WILL PUT**  
**ON SCHEDULE FOR REPAIR**

12-Rt 665 past the ball park road falling in just pass 600 intersection  
**WILL MONITOR PUT ON SCHEDULE TO REPAIR**

13-RT. 662 OFF RT 82 NEEDS BRUSH CUT AND SHOULDER WORK. **WILL SCHEDULE**  
**LABOR FOR BRUSH TO BE CUT**

14-RT 750 CAMPBELL ST. NEAR FORT GIBSON CHURCH TREES NEED TO BE CUT  
LIMBS HANGING OVER ROADWAY. **UNDER REVIEW**

15-RT 609 HIGH POINT ROAD EXIT RAMP COMING OFF RT. 58E NEEDS TO BE  
EXTENDED. **REFER TO RESIDENCY OFFICE**

16-RT 635 HORTON RIDGE NARROW ROAD CURVE NEEDS TO BE WIDNED. **NEED**  
**EXACT LOCATION** RABBIT HOLLOW RD. WHERE SCHOOL BUS SIGN IS LOCATED  
1/3 MILE FROM RT. 67 UP HORTON RIDGE. **CURVE HAS BEEN PREVIOUSLY**  
**WORKED**

17-RT 67 PUMPKIN CENTER KUDZU COVERING SIGNS

18-SMOOTS BRANCH DEEP FORES DR. POT HOLES AND PAVEMENT COMING UP

19-RT 82 CLEVELAND RD. .7/10 MILE BELOW RESCUE SQUAD LOWER SHOULDER  
DROPPING OFF ON THE LEFT SIDE OF ROAD

20- RT 607 BUFALLOW APPROXIMATELY 1 1/2 MILE FROM RT 611 NEAR HOUSE  
#496 AT THE BOTTOM OF THE HILL WATER HAS BEEN UP IN ROAD LEAVING MUD  
APPARENTLY THE DITCH NEEDS TO BE PULLED AND PIPE CLEANED. **UNDER**  
**REVIEW**

21-RT 657 EAST CROSSROADS SEVERAL POT HOLES ENTIRE ROAD

22-RT 683 NEEDS SPEED LIMIT SIGNS FROM CEMETERY TO RT. 58 BUZZARD ROOST. **REPORTED TO SIGN CREW**

23-RT65 BRUSH NEEDS TO BE CUT AT THE INTERSECTION OF RT.611

24-RT 82 PAST 2<sup>ND</sup> CURVE GOING DOWN THE MOUNTAIN ROAD BREAKING OFF INSIDE WHITE LINE. WILL PATCH AND MONITOR

25-RT 665 EDGE OF ROAD WASHING OUT. **WILL SCHEDULE FOR REPAIRS**

26-ARTRIP RD. 1/2 MILE FROM CLEVELAND BRIDGE BANK NEEDS TO BE TAKEN OFF TO WIDEN ROADWAY. **WILL REVIEW WITH RESIDENCY**

27- 4TH STREET CLEVELAND & BURNS AVE. STREET HAS GRADUALLY GOTTEN COVERED BY SLIDING THAT NOW IS COVERING 5 FEET OF THE PAVED STREET. NEEDS A RETAINING WALL TO PREVENT FURTHER EROSION. LOT OF TRAFFIC ON THIS STREET GOING TO TANK HOLLOW FALLS AND CHURCH TRAFFIC.

### **SCHOOL BUS SAFETY AND OTHER CONCERNS**

1- RT 67 AT SWORDS CREEK ELEMENTARY SCHOOL BUS SIGN COVERED OVER

### **ITEMS REPORTED CORRECTED**

1-RT 67 GUARD RAIL END REPLACED AT DAISY LANE PERKINS CHAPEL

2-RT 58/609 INTERSECTION WEEDS CUT FOR BETTER VISIBILITY

3-RT 621 SKEENS FORK PIPE REPLACED

4-RT 63 DANTE MTN, JUST BEFORE WATER TANK RD. ROAD REPAIRED

5- RT 604 MOLLS CR. POT HOLES PATCHED AND SPEED LIMIT SIGN

6-RT 640 GLADE HOLLOW RD. POT HOLE REPAIRED

7-RT 80 TREES HAVE BEEN CUT

8-RT 671 FLATS CIRCLE EMBANKMENTS REPAIRED

8-RT 678 UPPER COPPER CREEK GRADED AND GRAVEL

9-RT 645 NEW GARDEN RD. 1/40MILE FROM BRIDGE RUFF ROAD REPAIRED

**FUTURE MAJOR SAFETY PROJECTS**

1-RT 627 DANTE SAWMILL HOLLOW CURVE NEEDS WIDENED AT THE UPPER END NEAR THE BALLFIELD and also the one lane road near the R.R tracks TO HANDLE ANTICIPATED HEAVY TRAFFIC TO A CAMP SITE. COUNTY WORKING WITH VDOT A RIGHT OF WAY PROBLEM. POSSIBLE SMART SCALE PROJECT

2-58W CASTLEWOOD AT THE TRAFFIC LIGHTS ROAD HOOVES UP THAT COULD CAUSE A POTENTIAL HAZARD CONDITION. POSSIBLE RIP UP AND REPAVE WITH DIFFERENT MATERIAL

3-Rt. 71s / 604 Molls Creek INTERSECTION needs bank KEPT scaled back for visibility

4-Rt. 80 from the doubles to Rt. 19 needs a passing lane installed

5-Rt. 645 New Garden Road water undercutting road one mile East of Nash's Ford Bridge GETTING WORSE /PER TONY. **WILL SCHEDULE FOR REPAIR.TEMPORARY FIXED**

6-Rt. 19 south exits 1 coal tipple hollow ramp needs to be extended

**UNDER LINED AND BOLDED COMMENTS WERE REPORTED FROM HENRY KINCER**

**COMMISIOM MEMBER INFROMATION**

BARBARA COX	971 1502	JOHNNY JESSEE	889 1563
LINDA CROSS	794 7618	TIM LOVELACE	971 0367
GARY DOTSON	7 62 9803	TONY MAXFIELD	254 2492
EUGENE FERGUSON	210 8504	MIKE O'QUINN	701 7086
CARL RHEA	254 3810	HENRY STINSON	873 4905
HENRY KINCER	889 7601		

**NEXT MEETING WILL BE SEPTEMBER 21ST 2021 WE THANK ALL WHO ARE INVOLVED IN KEEPING OUR ROADWAYS SAFE AND OUR GUEST PARTICAPTION**

**SAFETY IS A COMMITMENT!!!!!!!!!!!!!!PREPARED BY GARY DOTSON**



## Cannery Revenue Report FY 2021/2022

### Castlewood

Month	Resident Customers	OutofCounty Customers	Combined Revenues	Resident Customers	Cans Used	Glass Jars	Non-Resident Customers	Cans Used	Glass Jars
July	10	5	\$ 157.65	\$ 43.85	0	249	\$ 113.80	0	585
August									
September									
October									
November									
December									
January									
<b>Total</b>	<b>10</b>	<b>5</b>	<b>\$ 157.65</b>	<b>\$ 43.85</b>	<b>0</b>	<b>249</b>	<b>\$ 113.80</b>	<b>0</b>	<b>585</b>

### Honaker

Month	Resident Customers	OutofCounty Customers	Combined Revenues	Resident Customers	Cans Used	Glass Jars	Non-Resident Customers	Cans Used	Glass Jars
July	10	2	\$ 79.10	\$ 53.20	0	255	\$ 25.90	0	74
August									
September									
October									
November									
December									
January									
<b>Total</b>	<b>10</b>	<b>2</b>	<b>\$ 79.10</b>	<b>\$ 53.20</b>	<b>0</b>	<b>255</b>	<b>\$ 25.90</b>	<b>0</b>	<b>74</b>

<b>Season Totals</b>			<b>Combined Revenues</b> \$ 236.75	<b>Total Resident</b> \$ 97.05	<b>Total Cans</b> 0	<b>Total Jars</b> 504	<b>Total Non-Resident</b> \$ 139.70	<b>Total Cans</b> 0	<b>Total Jars</b> 659
----------------------	--	--	---------------------------------------	-----------------------------------	------------------------	--------------------------	--	------------------------	--------------------------

## Dilapidated Structure and Litter Reported Sites

Address	Property Owner	Tax Map I.d.	Comments
4478 Red Oak Ridge Rd.Castlewood, VA 24224	Warren & Lesha Kiser	158 R SB 1831	3/1/2021: RC BOS voted and passed motion to proceed with legal action. 3/2/2021: Final notification issued and sent to property owner, via certified letter. No response from property owner to date
2625 Banner St. Paul, VA 24283	St. Beecher Mays & Brenda Hammons c/o Connie Jessee	157 L IB 3294	2/19/2021: Site Observation with R.C.S.O. --Notification of corrections to be completed to be sent to property owner. 4/19/2021: No contact/response from property owner. 06/30/2021:No contact/response from property owner. RC Building Official requests direction from BOS 7/26/2021: No contact/response from property owner. RC Building Official requests direction from BOS
Winchester Hotel	Timmy or Kristy Lee 14414 Marshalls Retreat Rd. St. Paul, VA 24283	157 R SA 1767	3/2/2021: 30 day Notice issued and sent to property owner via certified letter. Public Notice to appear in Lebanon News beginning 3/17/2021, ending 3/24/2021. 4/19/2021: No contact/response from property owner. 06/30/2021: No contact/response from property owner. RC Building Official requests direction from BOS 7/26/2021: No contact/response from property owner. RC Building Official requests direction from BOS

Gobble -- (Trailer)	Billy Wyane Mary Elizabeth Gobble P.O. Box 519 Castlewood, VA 24224-399	138 R 2328 B2	3/2/2021: 30 Day Notice issued and sent to property owner via certified letter. Public Notice to appear in Lebanon News beginning 3/17/2021, ending 3/24/2021. 4/19/2021: Per discussion with RC Building Official, previous property owner advised property information is incorrect. 06/30/2021: RC Building Dept. in process of attempting to obtain mobile home owner information.--
Tim & Rendy Hale	192 Lower Bear Wallow Dante, VA 24273	159 R IB 2189	3/1/2021: RC BOS voted and passed motion to proceed with legal action. 3/2/2021: Final Notification sent via Certified Letter 3/6/2021: Cert. letter recpt card received by RC Building Dept. 4/19/2021: RC Building Official observed property. 06/30/2021: No contact/response from property owner. RC Building Official requests direction from BOS 7/26/2021: No contact/response from property owner. RC Building Official requests direction from BOS
Calvin W. or Carla Elmore	960 Private Rd. # 6294 Palestine, TX 75801	159 R IB 2201	4/19/2021: RC Building Official observed property. 5/26/2021: Letter returned to sender, not claimed. 06/30/2021: No contact/response from property owner. RC Building Official requests direction from BOS 7/26/2021: No contact/response from property owner. RC Building Official requests direction from BOS



		<b>Dilapidated Structure and Litter Reported Sites</b>	
<b>Address</b>	<b>Property Owner</b>	<b>Tax Map I.d.</b>	<b>Comments</b>
4478 Red Oak Ridge Rd.Castlewood, VA 24224	Warren & Leshia Kiser	158 R SB 1831	08/31/2020: Building Official has made contact with Russell Co. Litter Officer to arrange a site visit.-- 10/26/2020: Proceed with legal action if R.C.B.O. recommends it. 11/30/2020:Proceed with legal action if R.C.B.O. recommends it. 12/17/2020:Proceed with legal action if R.C.B.O. recommends it
4982 Mew Rd. Castlewood, VA 24224	James D. Ratliff	156 L IA 336	10/26/2020: Has not yet been observed by R.C.B.D. 11/30/2020:Has not yet been observed by R.C.B.D. 12/17/2020:Has not yet been observed by R.C.B.D.
2625 Banner St. St. Paul, VA 24283	Beecher Mays & Brenda Hammons c/o Connie Jessee	157 L IB 3294	10/26/2020: Has not yet been observed by R.C.B.D. 11/30/2020 Has not yet been observed by R.C.B.D. 12/17/2020:Has not yet been observed by R.C.B.D.
106 Talbert St. Castlewood, VA 24224			10/26/2020: Forward to Russell County Sheriffs office for enforcement. 11/30/2020: Forward to Russell County Sheriffs office for enforcement. 12/17/2020:orward to Russell County Sheriffs office for enforcement.
Winchester Hotel			10/26/2020: Need to do further site visits R.C.B.D. 11/30/2020: Need to do further site visits R.C.B.D. 12/17/2020: Need to do further site visits R.C.B.D.

Washers and Dryers--Sun			10/26/2020: Forward to Russell County Sheriffs office for enforcement. 11/30/2020: Forward to Russell County Sheriffs office for enforcement. 12/17/2020: Forward to Russell County Sheriffs office for enforcement.
Lewis Property--Dante			10/26/2020: Forward to Russell County Sheriffs office for enforcement. 11/30/2020: Forward to Russell County Sheriffs office for enforcement. 12/17/2020: Forward to Russell County Sheriffs office for enforcement.
Gene Couch--Memorial Drive			R.C.B.O. cannot determine if a sinkhole has been cleaned out and filled in.

# Library Board of Trustees Meeting



Members Present			Members Absent
Judy Ashbrook	Karen Davis	Ann Monk	Sharon Sargent
Susan Breeding	Karen Herndon		
Yvonne Dye	Sherry Lyttle	Sharon Van Dyke	

Chair Karen Herndon called the meeting to order 20 July 2021 at 5:00 pm.

**Introductions:**

**Presentations:**

**Minutes:** Sharon VanDyke made and Karen Davis seconded a motion to approve the June minutes as distributed; motion passed.

**Communications:**

**Financial:** Judy Ashbrook made and Sherry Lyttle seconded a motion to approve the bills; motion passed.

**Staff Reports:**

**Unfinished Business:**

**New Business:** Sharon VanDyke makes and Yvonne seconded a motion to approve the ARPA grant; motion passed. Sherry Lyttle made and Ann Monk seconded a motion to accept the operating budget as presented; motion passed.

**Review and Summary:**

Sherry made and Ann seconded a motion to adjourn.

Respectfully submitted, Kelly McBride Delph

Secretary



CUMBERLAND PLATEAU RWMA:

Mr. Toby F. Edwards, Executive Director

BUCHANAN COUNTY:

Mr. Jeff Cooper  
Mr. Tim Hess



DICKENSON COUNTY:

Mr. Damon Rasnick  
Mr. Ronald Peters

RUSSELL COUNTY:

Mr. Carl Rhea  
Mr. Tim Lovelace

## Agenda

- I. **August 19, 2021 CPRWMA Board of Directors Roll Call for Quorum.**
- II. a) **Approval of Minutes of the July 17, 2021 meeting.....1**  
 Motion: \_\_\_\_\_ Seconded: \_\_\_\_\_
- b) **Approval of Minutes Special Called meeting August 11, 2021.....**
- III. **Administrative Business**
- a) **Review CPRWMA Waste Stream Report July 2021.....5**  
 Motion: \_\_\_\_\_ Seconded: \_\_\_\_\_
- b) **Approval of the Treasurer's Report for the month of July 2021.....13**  
 Motion: \_\_\_\_\_ Seconded: \_\_\_\_\_
- c) **CPRWMA Attorney's Report for July 2021.....Report**
- d) **Litter and Recycling Report.....Toby**
- IV. **Old Business**
- A) **Discussion Portable Tire Machine Purchase.**  
 Motion: \_\_\_\_\_ Seconded: \_\_\_\_\_
- V. **New Business**
- A) **Motion: \_\_\_\_\_ Seconded: \_\_\_\_\_**
- B) **Motion: \_\_\_\_\_ Seconded: \_\_\_\_\_**
- VI. **Correspondence**
- VA DEQ Inspection Dickenson Co Transfer Station**
- VII. **Adjournment and Next Meeting.**  
 Chair or Vice Chair conducting the meeting: \_\_\_\_\_  
 Motion: \_\_\_\_\_ Seconded: \_\_\_\_\_  
 Minutes submitted by: Ron Peters and Sandra Honaker

137 Highland Drive / P. O. Box 386 Lebanon, VA 24266  
 Phone 276-833-5403 Email tobyedwards@bvua.net  
 www.cprwma.com



**CUMBERLAND PLATEAU RWMA:**

Mr. Toby F. Edwards, Executive Director

**BUCHANAN COUNTY:**

Mr. Jeff Cooper  
Mr. Tim Hess



**DICKENSON COUNTY:**

Mr. Damon Rasnick  
Mr. Ronald Peters

**RUSSELL COUNTY:**

Mr. Carl Rhea  
Mr. Tim Lovelace

**Cumberland Plateau Regional Waste Management Authority  
Monthly Board Meeting Minutes  
July 21, 2021**

**Members Present:**

Jeff Cooper, Chairman  
Carl Rhea, Vice Chairman  
Ronald E Peters, Secretary/Treasurer  
Tim Hess  
Tim Lovelace  
Damon Rasnick

**Others Present:**

Toby Edwards, Director  
R.J. Thornbury, Legal Counsel  
P.C. Justice, Legal Counsel  
Michael "Bony" Shields, DC Transfer  
Brian Ferguson, RC Transfer  
Saundra Honaker, Finance  
Jeff Brown, Caterpillar Representative  
Justin Rodda, Waste Management  
Brandon Monroe, CEI Hauler

**CALL TO ORDER:** Chairman, Jeff Cooper, called the July 21, 2021 meeting of the Board of Directors to order at 5:16 PM. The Pledge of Allegiance and prayer was given.

**QUORUM:** A quorum was established.

**APPROVAL OF MINUTES:** The minutes of the June 17, 2021 monthly meeting of the Board of Directors were presented for consideration. A motion was made by Damon Rasnick and seconded by Ron Peters to approve the minutes as presented. Motion was ratified, voting as follows:

Tim Hess – Aye  
Tim Lovelace – Aye  
Ron Peters – Aye

Carl Rhea – Aye  
Jeff Cooper – Aye  
Damon Rasnick – Aye

**ADMINISTRATIVE BUSINESS**

**WASTE STREAM REPORTS – June 2021:** Toby Edwards reviewed the waste stream reports for June. Overall Buchanan and Dickenson showed a slight increase and Russell County a slight decrease for June.

**137 Highland Drive / P. O. Box 386 Lebanon, VA 24266  
Phone 276-833-5403 Email tobyedwards@bvumet.net  
www.cprwma.com**



TREASURER'S REPORT – June 2021: Ron Peters presented the CPRWMA Treasurer's Report for the month of June 2021, reporting the total cash balance was \$327,935.31 at the end of June. Some review of a couple bills was discussed. A motion to approve the report as presented was made by Tim Hess and seconded by Carl Rhea. Motion was ratified, voting as follows:

Tim Hess – Aye	Carl Rhea – Aye
Tim Lovelace– Aye	Jeff Cooper – Aye
Ron Peters – Aye	Damon Rasnick – Aye

CPRWMA ATTORNEY'S REPORT – June 2021: Rebecca Thornbury reported the new marijuana laws took effect in Virginia beginning July 1, 2021, addressing how it might affect the CPRWMA policy and worker's compensation. She recommended the Board update some language in the current employee handbook to comply with the new legislation. A motion was made by Ron Peters and seconded by Damon Rasnick for Rebecca to review the employee manual to update any wording that might be necessary to comply with the new law and present to the Board. Motion was ratified, voting as follows:

Tim Hess – Aye	Carl Rhea – Aye
Tim Lovelace– Aye	Jeff Cooper – Aye
Ron Peters – Aye	Damon Rasnick – Aye

LITTER AND RECYCLING REPORT: An HHW event has been scheduled for Buchanan in October. Dickenson and Russell may wait until next year because of the cost.

### **OLD BUSINESS**

REPAIRS TO THE TIRE SHEAR AND TIRE MACHINES Mr. Toby Edwards indicated that the tire machines are being overworked due to demand which is necessitating repairs and down time. He presented a proposal that the CPRWMA purchase a portable tire shredder that would alleviate some of the issues with the tires. The portable shredder would be shared among the three counties on a rotating basis. Mr. Edwards stated no additional employees are anticipated to use or rotate the machine. Total cost of the equipment is \$164,000 + \$2,000 (delivery and set-up incidentals). The Board would pay \$90,000 down and finance the remainder. Legal counsel advised that at least three bids for financing from financial institutions be secured before purchasing. Discussion ensued regarding whether the item has a single source supplier and necessary steps to purchase. If the supplier was on Sourcwell, a government purchase solicitation), then any procurement procedures would be met. If not, Mr. Lovelace suggested the CPRWMA join the E-VA program to acquire additional bids for the equipment. A motion was made by Ron Peters and seconded by Tim Lovelace that Mr. Edwards secure additional financing quotes, verify if the equipment company is a member of Sourcwell (government purchase solicitation) and if not, that



the CPRWMA join the Virginia E-VA program to advertise for additional bids for the equipment. Motion was ratified, voting as follows:

Tim Hess – Aye	Carl Rhea – Aye
Tim Lovelace– Aye	Jeff Cooper – Aye
Ron Peters – Aye	Damon Rasnick – Aye

TIRE EQUIPMENT SAVINGS 2020-21 Toby reviewed the sheet that was included in the board packet illustrating the savings to Buchanan/Dickenson/Russell counties on tire disposal. In eleven months, there was a total savings of \$30,651 due to the purchase and use of the tire cutting machines.

### **NEW BUSINESS**

EXECUTIVE DIRECTORS' YEARLY EVALUATION A motion was made by Tim Hess and seconded by Damon Rasnick to enter closed meeting pursuant to Section 2.2-3711 (A)(1) of the Code of Virginia to discuss personnel matters. Motion was ratified, voting as follows:

Tim Hess – Aye	Carl Rhea – Aye
Tim Lovelace– Aye	Jeff Cooper – Aye
Ron Peters – Aye	Damon Rasnick – Aye

Motion was made by Tim Hess and seconded by Damon Rasnick that the Board certify that only public business matters lawfully exempted from the open meeting requirements of the Virginia Freedom of Information Act and identified in the motion authorizing the closed session were heard, discussed or considered during the closed session.

. Motion was ratified, roll call voting as follows:

Tim Hess – Aye	Carl Rhea – Aye
Tim Lovelace– Aye	Jeff Cooper – Aye
Ron Peters – Aye	Damon Rasnick – Aye

A motion was made by Ron Peters and seconded by Damon Rasnick to approve the performance evaluation and a salary increase for Executive Director, Toby Edwards. Motion was ratified, voting as follows:

Tim Hess – Aye	Carl Rhea – Aye
Tim Lovelace– Aye	Jeff Cooper – Aye
Ron Peters – Aye	Damon Rasnick – Aye

A motion was made by Damon Rasnick and seconded by Ron Peters to approve a \$50.00 increase in payment to Sandra Honaker for accounting services. Motion was ratified, voting as follows:

Tim Hess – Aye	Carl Rhea – Aye
Tim Lovelace– Aye	Jeff Cooper – Aye
Ron Peters – Aye	Damon Rasnick – Aye

**CORRESPONDENCE**

No correspondence

**Guests:**

Jeff Brown from Caterpillar was present. There was discussion that new loaders were needed for all three counties. Mr. Brown indicated that he could go ahead and order the three loaders to lock in the current price, but the Board would be under no obligation to purchase. Additionally, there was some discussion regarding a different hookup for the buckets. Mr. Cooper inquired as to possible leasing of the equipment rather than purchase. Mr. Brown plans to attend the September meeting to further discuss these issues.

Justin Rodda, Waste Management Landfill Manager stated he anticipates that rates will increase in the coming years. He mentioned the purchase of Waste Management from Advanced Disposal and nothing should change in service. He extended an invitation to all Board members to visit the company.

Brandon Monroe, CEI stated he is currently working on putting on the tarps.

**ADJOURNMENT AND NEXT MEETING**

A motion was made by Ron Peters and seconded by Tim Hess to have the next meeting on August 19, 2021 at 5:00 PM at Keen Mtn Park and to invite the staff of the transfer stations and Toby to coordinate the meal. Motion was ratified, voting as follows:

Tim Hess – Aye	Carl Rhea – Aye
Tim Lovelace– Aye	Jeff Cooper – Aye
Ron Peters – Aye	Damon Rasnick – Aye

A motion was made by Carl Rhea and seconded by Damon Rasnick to adjourn the meeting at 6:55 PM. Motion was ratified, voting as follows:

Tim Hess – Aye	Carl Rhea – Aye
Tim Lovelace– Aye	Jeff Cooper – Aye
Ron Peters – Aye	Damon Rasnick – Aye

---

Secretary/Treasurer

---

Date

**CUMBERLAND PLATEAU RWMA:**

Mr. Toby F. Edwards, Executive Director

**BUCHANAN COUNTY:**

Mr. Jeff Cooper  
Mr. Tim Hess



**DICKENSON COUNTY:**

Mr. Damon Rasnick  
Mr. Ronald Peters

**RUSSELL COUNTY:**

Mr. Carl Rhea  
Mr. Tim Lovelace

**Cumberland Plateau Regional Waste Management Authority  
Special Meeting Minutes  
August 11, 2021**

Members Present:

Jeff Cooper, Chairman  
Carl Rhea, Vice Chairman  
Ronald E Peters, Secretary/Treasurer  
Tim Hess  
Tim Lovelace  
Damon Rasnick

Others Present:

Toby Edwards, Director  
R.J. Thornbury, Legal Counsel  
Saundra Honaker, Finance

CALL TO ORDER:

Chairman, Jeff Cooper, called the Special Meeting of the Board of Directors to order at 5:45 PM on August 11, 2021. The Special Meeting was called at the request of Chairman, Jeff Cooper, in accordance with Article III, Section 2 of the Cumberland Plateau Regional Waste Management Authority By-laws. The Pledge of Allegiance and prayer was given.

QUORUM: A quorum was established by roll call.

A motion was made by Tim Hess and seconded by Damon Rasnick to enter into closed meeting pursuant to Section 2.2-3711 (A)(8) of the Code of Virginia for legal advise regarding Waste Management, and that legal counsel, the Executive Director and Saundra Honaker attend the meeting, as they are deemed necessary and would aid the Board in its consideration.

Motion was ratified, roll call voting as follows:

Tim Hess – Aye	Carl Rhea – Aye
Tim Lovelace – Aye	Jeff Cooper – Aye
Ron Peters – Aye	Damon Rasnick – Aye

Motion made by Tim Hess and seconded by Damon Rasnick to reconvene in open session; Board voting unanimously.

Motion was made by Tim Hess and seconded by Damon Rasnick that the Board certify that only public business shall be conducted at the meeting.

187 Highland Drive, P.O. Box 386, Lebanon, VA 24266  
Phone 276-833-5103, Email toby.edwards@cprwma.net

[www.cprwma.com](http://www.cprwma.com)





Motion was ratified, roll call voting as follows:

Tim Hess – Aye	Carl Rhea – Aye
Tim Lovelace– Aye	Jeff Cooper – Aye
Ron Peters – Aye	Damon Rasnick – Aye

A motion was made by Damon Rasnick and seconded by Ron Peters to grant authorization to Toby Edwards, Jeff Cooper, and legal counsel, if necessary. to meet with Justin Rodda, District Manager, Eco-Safe Landfill to discuss the Environmental Recovery Fee, to determine the breakdown of the ERF and request more favorable start date and fee. Motion was ratified, voting as follows:

Tim Hess – Aye	Carl Rhea – Aye
Tim Lovelace– Aye	Jeff Cooper – Aye
Ron Peters – Aye	Damon Rasnick

#### **ADJOURNMENT**

A motion was made by Ron Peters and seconded by Damon Rasnick to adjourn the meeting at 6:45 PM. Motion was ratified, voting as follows:

Tim Hess – Aye	Carl Rhea – Aye
Tim Lovelace– Aye	Jeff Cooper – Aye
Ron Peters – Aye	Damon Rasnick – Aye

\_\_\_\_\_  
Secretary/Treasurer

\_\_\_\_\_  
Date





Cumberland Plateau Regional Waste Management Authority

**Russell County**

Waste Material(s)	Dec 20- Jan 2021	Jan 2021-Feb 2021	Feb 2021-March 2021	March 2021-April 2021	April 2021-May 2021	May 2021-June 2021	June 2021-July 2021	July 2021-Aug 2021	Aug 2021-Sept 2021	Sept 2021-Oct 2021	Oct 2021-Nov 2021	Nov 2021-Dec 2021	Totals from all Columns	Average (Per Month) Tonnage
Household	1,134.13	1,111.53	1,248.79	1,452.34	1,320.86	1,426.73	1,313.68	1,297.25	0.00	0.00	0.00	0.00	10,305.31	
Commercial	125.88	96.49	120.61	128.56	170.90	98.70	131.65	125.82	0.00	0.00	0.00	0.00	998.61	
Construction														
Debris	96.18	44.28	44.38	113.81	73.16	104.61	65.56	134.60	0.00	0.00	0.00	0.00	676.58	
Yard/Ash Waste	0.00	0.00	0.00	0.00	0.00	0.00	0.00	0.00	0.00	0.00	0.00	0.00	0.00	
Mine Waste	0.00	0.00	0.00	0.00	0.00	0.00	0.00	0.00	0.00	0.00	0.00	0.00	0.00	
Industrial Waste	24.74	26.23	31.44	36.86	26.15	30.29	34.21	30.70	0.00	0.00	0.00	0.00	240.62	
Roofing Waste	0.00	0.00	0.00	0.00	0.00	0.00	0.00	0.00	0.00	0.00	0.00	0.00	0.00	
Tires	21.47	8.52	14.06	10.55	39.40	25.26	13.86	17.18	0.00	0.00	0.00	0.00	150.30	
White Goods	0.00	2.59	0.00	9.31	5.50	0.00	0.00	0.00	0.00	0.00	0.00	0.00	17.40	
Pallates	0.00	0.00	0.00	0.00	0.00	0.00	0.00	0.00	0.00	0.00	0.00	0.00	0.00	
Dry Sludge	0.00	0.00	0.00	0.00	0.00	0.00	0.00	0.00	0.00	0.00	0.00	0.00	0.00	
Contaminated														
Recycle	0.00	0.00	0.80	0.00	0.00	0.00	0.00	0.00	0.00	0.00	0.00	0.00	0.80	
Illegal Dumpsite	3.93	0.00	0.96	5.76	0.72	13.40	14.19	16.84	0.00	0.00	0.00	0.00	55.80	
Storm Debris	0.00	0.00	0.00	0.00	0.00	0.00	0.00	0.00	0.00	0.00	0.00	0.00	0.00	
Carcass	1.41	2.30	4.35	0.88	0.84	0.48	1.39	0.60	0.00	0.00	0.00	0.00	12.25	
<b>Totals</b>	<b>1,407.74</b>	<b>1,291.94</b>	<b>1,465.39</b>	<b>1,758.07</b>	<b>1,637.53</b>	<b>1,699.47</b>	<b>1,574.54</b>	<b>1,622.99</b>	<b>0.00</b>	<b>0.00</b>	<b>0.00</b>	<b>0.00</b>	<b>12,457.67</b>	<b>1,557.21</b>
Town of Lebanon	0.00			0.00		0.00	0.00		0.00	0.00	0.00	0.00		
Town of Honaker	0.00											0.00		
Town of Cleveland	0.00			0.00		0.00	0.00		0.00	0.00	0.00	0.00		
													Total FY 2020-2021	35,376.47









Cumberland Plateau Waste Stream Analysis Report

Dickenson County Waste Stream Analysis  
Period: July 16th, 2021 to August 15, 2021

Name of Waste Material	This Month (Tons)	Last Month (Tons)	2020 (Tons)	2019 (Tons)	2018 (Tons)	2017 (Tons)	2016 (Tons)	2015 (Tons)	2014 (Tons)	2013 (Tons)	2012 (Tons)	2011 (Tons)	2010 (Tons)	2009 (Tons)	2008 (Tons)	2007 (Tons)	2006 (Tons)
Household	607.05	652.89	647.42	693.47	687.66	637.30	623.73	666.93	683.66	682.05	743.08	653.54	686.53	826.24	853.19	849.57	806.45
Commercial	133.02	200.34	126.36	147.08	90.32	27.96	46.11	98.06	116.67	25.31	36.29	24.00	177.46	137.64	53.77	5.79	3.46
Construction Debris	47.77	28.33	27.26	16.58	3.78	1.85	7.57	20.13	8.52	24.95	22.64	3.14	15.04	28.01	55.49	60.62	28.13
Yard Waste	0.00	0.00	0.00	0.00	0.00	0.00	0.00	0.00	0.08	0.00	0.00	0.07	0.04	0.00	26.29	22.42	1.95
Mine Waste	202.64	205.09	226.67	253.20	186.59	166.08	108.34	220.18	332.24	527.97	440.15	260.87	89.65	73.78	224.19	187.18	87.36
Industrial Waste	0.00	0.00	0.00	0.00	0.00	0.00	0.00	0.00	0.00	0.00	0.00	0.00	0.00	0.00	0.00	0.00	0.00
Roofing Waste	0.00	0.00	0.00	9.68	4.88	9.13	0.68	7.68	0.99	0.42	9.08	31.09	21.74	0.39	13.73	28.07	8.72
Tires	16.33	17.00	12.74	12.25	8.25	14.12	5.71	10.89	14.70	11.48	16.50	22.44	10.05	10.59	16.82	12.79	23.66
Storm Debris	0.00	0.00	0.00	0.00	0.00	0.00	0.00	0.00	0.00	0.00	0.00	0.00	0.00	0.00	0.00	0.00	0.00
Carcass	0.06	0.05	0.22	1.12	0.22	0.23	0.94	1.91	3.55	0.98	1.49	1.53	1.79	2.53	1.71	1.94	1.76
Other Dry Sludge	0.00	0.00	0.00	0.00	0.00	0.00	0.00	0.00	0.00	0.00	0.00	0.00	0.00	0.00	0.00	109.25	0.00
Mulch	0.00	0.00	0.00	0.00	0.00	0.00	0.00	0.00	0.00	0.00	0.00	0.00	0.00	0.00	0.00	1.64	0.61
Illegal Dumps/Litter Pickup	1.63	0.53	3.22	1.38	0.00	0.00	0.00	0.00	0.00	0.00	0.00	0.00	0.00	0.00	0.31	4.34	0.00
	1,008.50	1,104.23	1,043.89	1,134.76	981.70	856.67	793.08	1,025.78	1,160.41	1,273.16	1,269.21	996.68	1,002.30	1,079.18	1,245.50	1,283.61	962.10

Dickenson County Waste Stream Analysis  
(This Month)

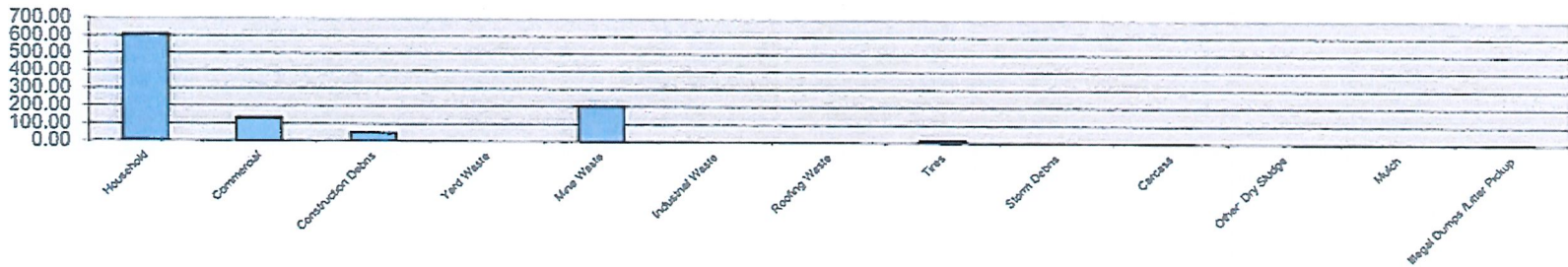

Total Tonnage includes the following towns:

Town of Clintwood

0















Cumberland Plateau Regional Waste  
Management Authority

Cash Flow Statement

July 2021

<b>Cash Balance - June 30, 2021</b>		<b>327,935.31</b>
<b>Cash Received - Tipping Fees:</b>		
Buchanan (June)	51,195.72	
Dickenson (June)	40,715.99	
Russell (June)	48,700.41	
		<b>140,612.12</b>
<b>Cash Expenditures</b>		
Cash Expenditures - July 2021		<b>(211,225.17)</b>
<b>Cash Balance - July 31, 2021</b>		<b>257,322.26</b>

*Fund Balances:*

<i>Capital Equip Replacement Fund</i>	<i>\$247,810</i>
<i>DEQ C/D</i>	<i>\$25,000</i>

**Cumberland Plateau Regional  
Check Register  
For the Period From Jul 1, 2021 to Jul 31, 2021**

Filter Criteria Includes: Report order is by Check Number.

Check #	Date	Payee	Amount
	7/1/21	Arihem HealthKeepers, Inc.	704.88 Toby's Health/Vision/Dental
	7/21/21	Caterpillar Financial Services Corp	6,218.75 Note Payment
	7/8/21	TAG Resources, LLC	233.33 Employee 401k
	7/21/21	TAG Resources, LLC	233.33 Employee 401k
13363	7/8/21	Verizon	169.81 RC Phone
13364	7/8/21	VACORP	14,114.00 Annual Insurance Premium
13365	7/8/21	Point Broadband	85.99 DC Phone
13366	7/8/21	Point Broadband	60.50 Office Phone
13367	7/8/21	Appalachian Power Company	249.71 BC Electric
13368	7/8/21	Cox Security Services	323.91 BC/DC RC Security \$107.67 each
13369	7/8/21	Unifirst Corporation	342.39 Uniforms
13370	7/8/21	Mansfield Oil Company	82.02 Vehicle Fuel
13371	7/8/21	Virginia Recycling Association	350.00 Conference
13372	7/8/21	Rubberedge	4,558.33 BC Equip Maint \$1,519.44 DC Equip Maint \$1,519.44 RC Equip Maint \$1,519.45
13373	7/8/21	83 Gas & Grocery, Inc.	1,189.24 DC Fuel
13374	7/8/21	Virginia Dept of the Treasury	650.00 Public Official Insurance
13375	7/8/21	Crystal Springs	19.70 RC Supplies
13376	7/21/21	Verizon	83.48 BC Phone
13377	7/21/21	Card Services Center	480.00 DC Equip Maint (Butty)
13378	7/21/21	Appalachian Power Company	44.25 RC Electric
13379	7/21/21	Appalachian Power Company	180.21 RC Electric
13380	7/21/21	Overhead Door Co of JC	885.00 BC Sta Maint \$520 DC Sta Maint \$345
13381	7/21/21	Appalachian Power Company	232.82 DC Electric
13382	7/21/21	Justice Law Office	585.74 Legal Jun/21
13383	7/21/21	Mansfield Oil Company	78.47 Vehicle Fuel
13384	7/21/21	Honaker Solutions, LLC	750.00 Accounting Jul/21
13385	7/21/21	Industrial Development Authority	200.00 Office Rent Aug/21
13386	7/21/21	Central Scale, Inc.	1,429.20 BC Sta Maint \$600 DC Sta Maint \$829.20
13387	7/21/21	Buchanan County PSA	49.83 BC Utility
13388	7/21/21	Dickenson Co Public Service Authority	40.00 DC Utility
13389	7/21/21	Pest Control Plus, Inc.	120.00 Pest BC/DC/RC \$40 each
13390	7/21/21	Verizon	36.33 RC Phone
13391	7/21/21	Carter Machinery Company, Inc.	3,335.12 BC Equip Maint
13392	7/21/21	WM Corporate Services, Inc.	155,442.52 BC Tipping/Haul \$58,873.84 DC Tipping/Haul \$39,252.33 RC Tipping/Haul \$57,316.35
13393	7/21/21	WM Corporate Services, Inc.	2,475.81 BC/DC/RC Extra Tipping Fee
13394	7/21/21	Ferrellgas	542.83 DC Fuel
13395	7/21/21	Pump House Supply	394.22 RC Equip
13396	7/21/21	Point Broadband	91.44 Office Phone
13397	7/21/21	Point Broadband	87.57 DC Phone
13398	7/30/21	Unifirst Corporation	489.73 Uniforms
13399	7/30/21	Innovative Technology Solutions	480.00 IT Support
13400	7/30/21	Northern Tool & Equipment	614.50 BC Supplies \$204.83 DC Supplies \$204.83 RC Supplies \$204.84
13401	7/30/21	Skyline Fabricating, Inc.	955.00 BC Sta Maint \$478 DC Sta Maint \$238 RC Sta Maint \$239
13402	7/30/21	Verizon	77.35 RC Phone
13403	7/30/21	Alderson Construction	545.00 DC Sta Maint \$325 BC Sta Maint \$220
13404	7/30/21	Postmaster	220.00 4 Rolls Stamps
13405	7/30/21	Sign Shop	65.00 DC Sign
13406	7/30/21	Addington Oil, Inc	2,453.03 BC Fuel
13407	7/30/21	Carter Machinery Company, Inc.	429.73 RC Fuel \$381.84 BC Fuel \$68.09
13408	7/30/21	Ferrellgas	30.88 BC Fuel
13409	7/30/21	Advance Auto	137.84 RC Supplies
8.16.21	7/31/21	United States Treasury	1,445.76 Federal Withholding
8.26.21	7/31/21	VA Dept of Taxation	282.96 State Withholding
PR7121	7/1/21	Ronald E. Peters	184.70 Director's Compensation
PR7121	7/1/21	Damon Rasnick	184.70 Director's Compensation
PR7121	7/1/21	Tim Lovelace	184.70 Director's Compensation
PR7121	7/1/21	Carl Rhee	184.70 Director's Compensation
PR7121	7/1/21	Jeffery S. Cooper	184.70 Director's Compensation
PR7121	7/1/21	Timothy W. Hess	184.70 Director's Compensation
PR71521	7/15/21	Toby F. Edwards	2,391.34 Toby Salary 1st half
PR73021	7/31/21	Toby F. Edwards	2,500.12 Toby Salary 2nd half
<b>Total</b>			<b>211,225.17</b>

15



CUMBERLAND PLATEAU REGIONAL WASTE MANAGEMENT AUTHORITY  
FY 2021-22 - OPERATING BUDGET & EXPENSE REPORT

	Expenditures	FY 2021-22	
	Thru 7/31/2021	Budget	
<b>Direct Expenses:</b>			
Transport/Disposal	157,918.33	1,482,992.00	
Tire Recycling	-	15,000.00	
HHW Event	-	12,000.00	
Other Reimbursed Expenses	-	-	
	157,918.33	1,509,992.00	
<b>Overhead Expenses:</b>			
Debt Service - Loaders	6,218.75	75,000.00	8%
Other Disposal	-	2,000.00	0%
<b>Utilities:</b>			
Buchanan	299.54	5,100.00	6%
Dickenson	272.82	4,500.00	6%
Russell	224.46	4,500.00	5%
<b>Supplies:</b>			
Buchanan	204.83	2,500.00	8%
Dickenson	204.83	2,500.00	8%
Russell	362.38	2,500.00	14%
<b>Fuel:</b>			
Buchanan	2,552.00	7,000.00	36%
Dickenson	1,732.07	4,500.00	38%
Russell	68.09	7,000.00	1%
<b>Telephone:</b>			
Buchanan	191.45	1,500.00	13%
Dickenson	281.53	1,100.00	26%
Russell	391.46	2,000.00	20%
<b>Station Maintenance/Improvements:</b>			
Buchanan	1,858.00	30,000.00	6%
Dickenson	1,777.20	30,000.00	6%
Russell	279.00	30,000.00	1%
<b>Loader/Equip Maintenance:</b>			
Buchanan	4,854.56	23,000.00	21%
Dickenson	1,979.44	23,000.00	9%
Russell	2,207.22	23,000.00	10%
<b>Transfer Station Permits and Management:</b>			
Station Permits		20,000.00	0%
VACO Insurance	14,664.00	18,000.00	81%
Management & Fringe	7,608.12	90,000.00	8%
Finance Manager	750.00	9,000.00	8%
Legal	585.74	12,000.00	5%
IT Support	460.00	4,000.00	12%
Office Rental/Internet/Cell/Office Supplies	601.94	5,000.00	12%
Directors Comp & PR Tax	1,291.80	18,100.00	7%
Professional Fees (Audit)	-	7,200.00	0%
Meeting Expense	-	3,000.00	0%
Travel	350.00	1,000.00	35%
Supplies:	-	1,000.00	0%
Dues/licenses	-	400.00	0%
Vehicle Expense	158.49	2,500.00	6%
Uniform Rentals	812.12	4,000.00	20%
Advertising	65.00	2,000.00	3%
Projects-Tire Shear DC&RC	-	20,000.00	0%
Reserves/Equip/ Emergency Fund	-	2,000.00	0%
<b>OVERHEAD SUBTOTAL</b>	<b>53,306.84</b>	<b>499,900.00</b>	
Tire Machines/Shearer		-	
<b>TOTAL EXPENSES</b>	<b>211,225.17</b>	<b>2,009,892.00</b>	

<b>*Management Breakdown</b>	
Toby Health	704.88
Toby Salary	5979.17
401K Cost/Contribution	466.66
Taxes	457.41
	7608.12
<b>Directors Comp &amp; Taxes</b>	
Salary	1200
Taxes	91.8
	1291.8
<b>Office Breakdown</b>	
Phone/int	181.94
Rent	200.00
Postage	220
Office Sup	
	601.94

Rate begins July 1st

13,886.11

\*\*Overhead Rate per County

# Itemized Equipment Proposal 8-3-2021

PD1000 Base Quote

Toby Edwards

Cumberland Plateau Regional Solid Waste.

276-883-5403

Tobyedwards@bvu.net

Note that this equipment is specified based on primary tire shredding to a 2" x variable length chip(primary shred). It will also shred wood pallets , papers, plastics, auto fluff, metals ferrous and non-ferrous, box springs and electronics. Semi tires may be processed after quartering or sidewall removal. This machine will process 4 to 5 tons per hour in dense materials. This machine may be operated outdoors as specified . Delivery in 14 to 16 weeks.

(1) **BCA Custom configured PD1000 primary portable dual shaft shredder. 140 HP John Deere Turbo-diesel (Tier 4) powered hydraulic high torque shredder. 36" rough top infeed conveyor and a 24" x 9'6" height for discharge chevron folding out-feed conveyor exhausting toward front of trailer. All PLC controlled and overload protected with electronic engine diagnostics. Auto-Reverse standard on Hydraulic equipment. 36" x 30" cutting chamber (raised 6" from stock) with 2" 4 hook knives on 5" 6 keyed shafts for no shaft washout. Modular BCA head can be swapped in 1 hour for sharpening knife maintenance . Will process, wood pallets, plastics, metals etc. and up to a 20" diameter rim tire LDT tire and quartered semi tires with bead removed or treads. Includes 2 year engine warranty from manufacturer**

\$ 163,000.00 Base

(1) **Sart-up kit includes mounted tool box with adjustment tools, grease gun, lube supplies, maintenance instructions and 2 of each 5 filters needed.**

\$ 800.00

**OPTIONS:** To minimize downtime at head maintenance:

An extra set of 2" x 14.5" AR5000 Ultra hard face welded knives	\$ 12,100.00
An extra set of hard face 2" spacers	\$ 2,160.00

\$ 163,800.00

**FOB OUR DOCK**

PD1000 with folding conveyor out-feed to side of system for roll-off container disposal.



Purchase of Tire Shredder  
To be used by all 3 counties

First Bank & Trust

Total Cost	\$166,000	
Pay down from capital Equipment Fund		\$90,000
Remaining Balance	\$76,000	

Finance Remainder		
1% over savings account		
for 60 months		
	Payments	
	\$1303 x 60 months	\$78,180

Total Cost to Board	\$168,180
---------------------	-----------





Sandra Honaker <honaker76@gmail.com>

---

## Cumberland Plateau Financing

3 messages

---

Justin L. Trent <jtrent@firstbank.com>  
To: "honaker76@gmail.com" <honaker76@gmail.com>

Fri, Jul 23, 2021 at 3:15 PM

Good Afternoon Ms. Honaker,

Thanks for the call today. The structure of the loan would be \$76,000 for 60 months with monthly payments secured by \$76,000 of cash in the current or new savings account. The rest of the funds would be available in the account. I can do a 1.00% variable rate over the current savings account rate. So if the savings account rate is 0.10% the loan rate would be 1.10%. If the savings rate goes higher or lower the loan rate will float with it. So effectively you are paying 1.00%. I will need the following to get this loan completed.

1. Board Meeting Minutes approving the loan and showing the signer or signers for Cumberland Plateau Regional Waste
2. Board Meeting Minutes showing if you want to use your current savings account or open a new one for this loan.

Thanks so much!

### Justin L Trent

Assistant Vice President / Commercial Lender

NMLS # 1648305



359 West Main Street | PO Box 457 | Lebanon, VA 24266

Tel (276) 889-4622 | Cell (276) 880-5291 | Fax (276) 889-4625

[www.firstbank.com](http://www.firstbank.com)



Saundra Honaker <honaker76@gmail.com>  
To: "Justin L. Trent" <jtrent@firstbank.com>

Fri, Jul 23, 2021 at 3:41 PM

Thanks so much. Could you send me the estimated monthly payment also, since we changed the loan amount?  
[Quoted text hidden]

—  
Saundra Honaker

---

Justin L. Trent <jtrent@firstbank.com>  
To: Saundra Honaker <honaker76@gmail.com>

Fri, Jul 23, 2021 at 3:45 PM

Around \$1,303. If the rate goes up or down the final payment at maturity will adjust accordingly.

Thanks!

[Quoted text hidden]

**Purchase of Tire Shredder**  
**To be used by all 3 counties**

**BB&T**

Total Cost	\$166,000	
Pay down from capital Equipment Fund		\$90,000
Remaining Balance	\$76,000	
Finance Remainder		
1.88% interest for 60 months		
Quarterly Payments		
\$3990 x 20 Quarters		\$79,800
Total Cost to Board		\$169,800





Saundra Honaker <honaker76@gmail.com>

---

**FW: Cumberland Plat. Reg. Waste Management Auth., VA RE: Ball Park Interest Rates #secure#**

1 message

---

tobyedwards@bvum.net <tobyedwards@bvum.net>  
Reply-To: tobyedwards@bvum.net  
To: Saundra Honaker <honaker76@gmail.com>

Wed, Jul 21, 2021 at 12:50 PM

Saundra,

Can you do the same spreadsheet that you did for First Bank and Trust for BB&T?

Email it and I will print off for the board.

**Toby F. Edwards, MsED**

Executive Director

Cumberland Plateau Regional Waste Management Authority

135 Highland Drive, Suite C

Lebanon, VA 24266

Telephone (276) 883-5403

Cell 276) 698-9414

www.cprwma.com

From: Akers, Rusty <Rusty.Akers@BBandT.com>

Sent: Wednesday, July 21, 2021 12:03 PM

To: tobyedwards@bvum.net

Subject: Cumberland Plat. Reg. Waste Management Auth., VA RE: Ball Park Interest Rates #secure#

Toby. Again, as in 2008, it was nice talking with you. As we discussed today, for the tire shredding machine, if the Authority is borrowing \$76,000 for five years, the indicative interest rate would be a bank qualified rate of 1.88%. Based upon these terms, a quarterly payment would be \$3,990 (rounded). Please let me know if you need anything else once you have your Board meeting. Have a great afternoon. Rusty

**Rusty Akers**

**Vice President**

**BB&T now Truist**

352 State Route 34  
Hurricane, WV 25526  
Phone: (304) 353-1635  
Fax: (304) 757-2768

*The information contained in this transmission is confidential and may be subject to protection under law. The message is intended for the sole use of the individual or entity to whom it is addressed. If you are not the intended recipient, you are notified that any use, distribution or copying of the message is strictly prohibited. If you received this message in error, please contact the sender immediately by replying to this e-mail and delete the material from any computer.*

**From:** tobyedwards@bvu.net <tobyedwards@bvu.net>  
**Sent:** Wednesday, July 21, 2021 11:58 AM  
**To:** Akers, Rusty <Rusty.Akers@BBandT.com>  
**Subject:** RE: Ball Park Interest Rates

Per our conversation.

## **Toby F. Edwards, MsED**

**Executive Director**

**Cumberland Plateau Regional Waste Management Authority**

**135 Highland Drive, Suite C**

**Lebanon, VA 24266**

**Telephone (276) 883-5403**

**Cell 276) 698-9414**

**[www.cprwma.com](http://www.cprwma.com)**

**From:** Akers, Rusty <Rusty.Akers@BBandT.com>  
**Sent:** Friday, November 14, 2008 3:55 PM  
**To:** toby@cprwma.com  
**Cc:** Hawkins, Cathy <Cathy.Hawkins@BBandT.com>  
**Subject:** Ball Park Interest Rates

Toby: It was nice talking with you. As we discussed, for budgeting purposes, the ball park interest rate for a \$1.3 million loan to be repaid over 15 years would be in the 4.40% range. Assuming this looks like an option the authority would like to pursue, we would need to review the 2006 and 2007 audits to make a credit decision. Hope this helps. Have a great weekend, Rusty

### **Rusty Akers**

501 Tennessee Avenue  
Charleston, WV 25302  
Phone: (304) 353-1635  
Fax: (304) 340-4702

Purchase of Tire Shredder  
To be used by all 3 counties

TruPoint

Total Cost	\$166,000	
Pay down from capital Equipment Fund		\$90,000
Remaining Balance	\$76,000	

Finance Remainder 3.65%, 1/2 point fee for 60 months		
	Payments 1383.63 x 60 months	\$83,018

Total Cost to Board	\$173,018
---------------------	-----------





Sandra Honaker <honaker76@gmail.com>

**FW: Loan(confidential)**

2 messages

**Toby Edwards** <tobyedwards@bvu.net>  
To: Sandra Honaker <honaker76@gmail.com>

Tue, Jul 27, 2021 at 2:19 PM

Sandra

Tru Point bank rate below.

As for lenders this has us complicated.

Thanks,

Toby F. Edwards, MsED  
Executive Director  
Cumberland Plateau Regional Waste Authority  
135 Highland Drive Suite C/PO BOX 385  
Lebanon VA 24266  
Office 276-883-5403  
Mobile 276-698-9411  
www.cprwma.com

Sent from my Verizon Samsung Galaxy smartphone



----- Original message -----

From: "Belcher, Regina" <Regina.Belcher@TruPointBank.com>  
Date: 7/27/21 1:02 PM (GMT-05:00)  
To: ""tobyedwards@bvu.net"" <tobyedwards@bvu.net>  
Subject: FW: Loan(confidential)

Toby,

Please see below the rate that TruPoint will offer for the loan that you requested.

Please let me know if this is acceptable and I will be glad to work with you and let you know what I need to proceed.

Many Thanks,

Regina

Regina D. Belcher  
Vice President & Commercial Relationship Manager  
276-623-5600 Fax - 276-623-5200 Office  
NMLS: 213631  
 TruPoint Bank

Dear Regina,

It was good chatting with you this evening.

Per our conversation, my Waste Authority is pursuing the purchase of a regional Tire Shredding machine to manage our tires in Buchanan Dickenson and Russell Counties. The quote is for \$166,000. The Authority will be putting down \$90,000 and we are looking to finance the balance of \$76,000 for 60 months.

Could you provide me your interest rate, monthly or quarterly payment amount and if it's a fixed rate.

Thanks,

Toby F. Edwards, MsED

Executive Director

Cumberland Plateau Regional Waste Authority

135 Highland Drive Suite C

Lebanon, VA 24266

Office 276-883-5403

Mobile 276-698-941

[www.cprwma.com](http://www.cprwma.com)

Sent from my Verizon, Samsung Galaxy smartphone

This message was secured by Zix<sup>®</sup>.

**tobyedwards@bvum.net** <tobyedwards@bvum.net>  
Reply-To: tobyedwards@bvum.net  
To: Sandra Honaker <honaker76@gmail.com>

Wed, Aug 11, 2021 at 11:39 AM

**Toby F. Edwards, MsED**

**Executive Director**

**Cumberland Plateau Regional Waste Management Authority**

Purchase of Tire Shredder  
To be used by all 3 counties

New Peoples Bank

Total Cost	\$166,000	
Pay down from capital Equipment Fund		\$90,000
Remaining Balance	\$76,000	

Finance Remainder @ Fixed 4.75% for 60 months		
	Payments	
	\$1428.03 x 60 months	\$85,682

Total Cost to Board	\$175,682
---------------------	-----------





Sandra Honaker <honaker76@gmail.com>

---

## Cumberland Plateau Waste Management Authority

2 messages

---

Richard Smith <RichardS@newpeoples.bank>  
To: "honaker76@gmail.com" <honaker76@gmail.com>

Fri, Jul 23, 2021 at 5:14 PM

It was a pleasure to speak with you today and I appreciate the opportunity to work on this project. To recap our discussion from my understanding you will be purchasing a new Tire Shredder at a cost of \$166,000.00. You plan to pay \$90,000.00 down on the unit and finance \$76,000.00 for a period of 60 months. Our rate for this term would be fixed at 4.75% and yield a payment of approximately \$1,428.03.

Again, I look forward to working with you on this acquisition and should you have further questions e-mail me or call on my direct line at 276-345-9332.

---

Sandra Honaker <honaker76@gmail.com>  
To: Toby Edwards <tobyedwards@bvu.net>, Rebecca Thornbury <rjtjlo@gmail.com>

Mon, Jul 26, 2021 at 12:24 PM

[Quoted text hidden]

--  
Sandra Honaker



*Commonwealth of Virginia*

**VIRGINIA DEPARTMENT OF ENVIRONMENTAL QUALITY**

SOUTHWEST REGIONAL OFFICE  
355-A Deadmore Street, Abingdon, Virginia 24210  
(276) 676-4800 FAX (804) 698-4178  
[www.deq.virginia.gov](http://www.deq.virginia.gov)

Matthew J. Strickler  
Secretary of Natural and Historic Resources

David K. Paylor  
Director  
(804) 698-4000

Jeffrey Hurst  
Regional Director

July 26, 2021

Mr. Toby F. Edwards  
Director of Waste Services  
Cumberland Plateau Regional Waste Management Authority  
P.O. Box 386  
Lebanon, Virginia 24266

**NO DEFICIENCY LETTER**

Re: Dickenson County Solid Waste Transfer Station  
Permit by Rule ("PBR") Number 049

Dear Mr. Edwards:

On July 23, 2021 the Virginia Department of Environmental Quality Southwest Regional Office staff conducted a compliance inspection of the solid waste management facility operating under PBR049. During the inspection, the facility was evaluated for compliance with the Virginia Waste Management Act, Va. Code § 10.1-1400 *et seq.* ("Act"), the Virginia Solid Waste Management Regulations, 9 VAC 20-81-10 *et seq.* ("Regulations"), and PBR049.

During this inspection, no apparent violations of the Act, Regulations, or PBR049 were observed. A copy of the inspection checklist is enclosed.

If you have any questions, please contact me at (276) 676-4840 or [stephan.martin@deq.virginia.gov](mailto:stephan.martin@deq.virginia.gov).

Sincerely,

*Stephan Martin*

Stephan Martin  
Solid Waste Compliance Inspector

Copy: Facility File (PBR049)



## Compliance Inspection Report

### Inspection Summary

**Facility:** Dickenson County Transfer Station  
**Permit:** PBR049  
**Region:** Southwest  
**Inspection Type:** Compliance Evaluation Inspection  
**Facility Staff:** Kevin Kiser

**Inspector:** Stephan Martin  
**Inspection Date:** 7/23/2021  
**Approximate Arrival Time:** 9:00 am  
**Inspection Method:** Unannounced  
**Exit Interview:** Yes  
**Weather Conditions:** clear

### Transfer Station (Active)

Reference	Description	SL	Result
<b>Compliance Area: Operator Information</b>			
10.1-1408.1	Disclosure Statement	I	
10.1-1408.2	Operator Certification	II	✓
<b>Compliance Area: Recordkeeping, Reporting &amp; Permit</b>			
20-81-80	Waste Assessment Program	II	
20-81-300.B	Compliance with the facility's permit	II	✓
20-81-300.F	Unauthorized waste program and inspection	II	✓
20-81-350	Facility Self-Inspections and Recordkeeping	I	✓
20-81-485.B	Operations Manual	I	✓
20-81-530.C	Permittee reporting requirements	II	
<b>Compliance Area: Design, Construction &amp; Operation</b>			
20-81-330.B	Facility design / construction	I	
20-81-340.B.1-3,5	Waste handling procedures / operations	II	✓
20-81-340.B.4	Management of leachate / washwater	III	✓
20-81-610-660	Special Waste	II	
<b>Compliance Area: Closure</b>			
20-81-360	Closure requirements	II	

SL = Severity Level      ✓ = In Compliance      X = Alleged Violation      N/A = Not Applicable      Blank = Not Inspected

### General Comments

Reference	Comments
10.1-1408.2	Operator Certification - The facility operators are listed at the end of this report.
20-81-300.B	Compliance with the facility's permit - The facility is operated well below its permitted 200 ton per day.
20-81-300.F	Unauthorized waste program and inspection - Random inspection log was provided for 2021. The inspections include the inspector's initial, and are dated.
20-81-350	Facility Self-Inspections and Recordkeeping - The facility provided its monthly inspections for 2021, as well as a representative sample of its daily checklists.
20-81-485.B	Operations Manual - The operations manual was certified current by Toby Edwards.
20-81-340.B.1-3,5	Waste handling procedures / operations - No putrescible waste is left on the tipping floor at the end of a working day. The facility has a contingency plan if needed.
20-81-340.B.4	Management of leachate / washwater - Leachate and waste water is channeled to holding tanks, and hauled to the the WWTP as needed. Records showing the hauling were made available upon request showing regular proper disposal.

### Disclosure Statement Details



**Key Personnel****Title**

Toby Edwards

Director CPRSWMA

**Waste Management Facility Operators****Licensed Operator****License #****Expiration Date**

Ellis Scott Jones

4605003161

11/30/2021

Kevin Kiser

4605002059

8/31/2022

Michael Leroy Shields

4605003859

9/30/2022

PLEASE advise the Regional Office within 10 calendar days if any information noted in this report is incorrect, if you have taken appropriate action to meet compliance, or if there is other information that the department should consider regarding any alleged violations.

PLEASE be advised that this report is not an agency proceeding or determination which may be considered a case decision under the Administrative Process Act (VA Code 2.2-4000 et seq). If informal discussions do not lead to a satisfactory conclusion on the contents of this report, you may request in writing that DEQ take all necessary steps to issue a final decision or fact finding under the APA on whether or not a violation has occurred.